

**FMS**

**1/10 TOYOTA  
LC80  
LAND CRUISER**

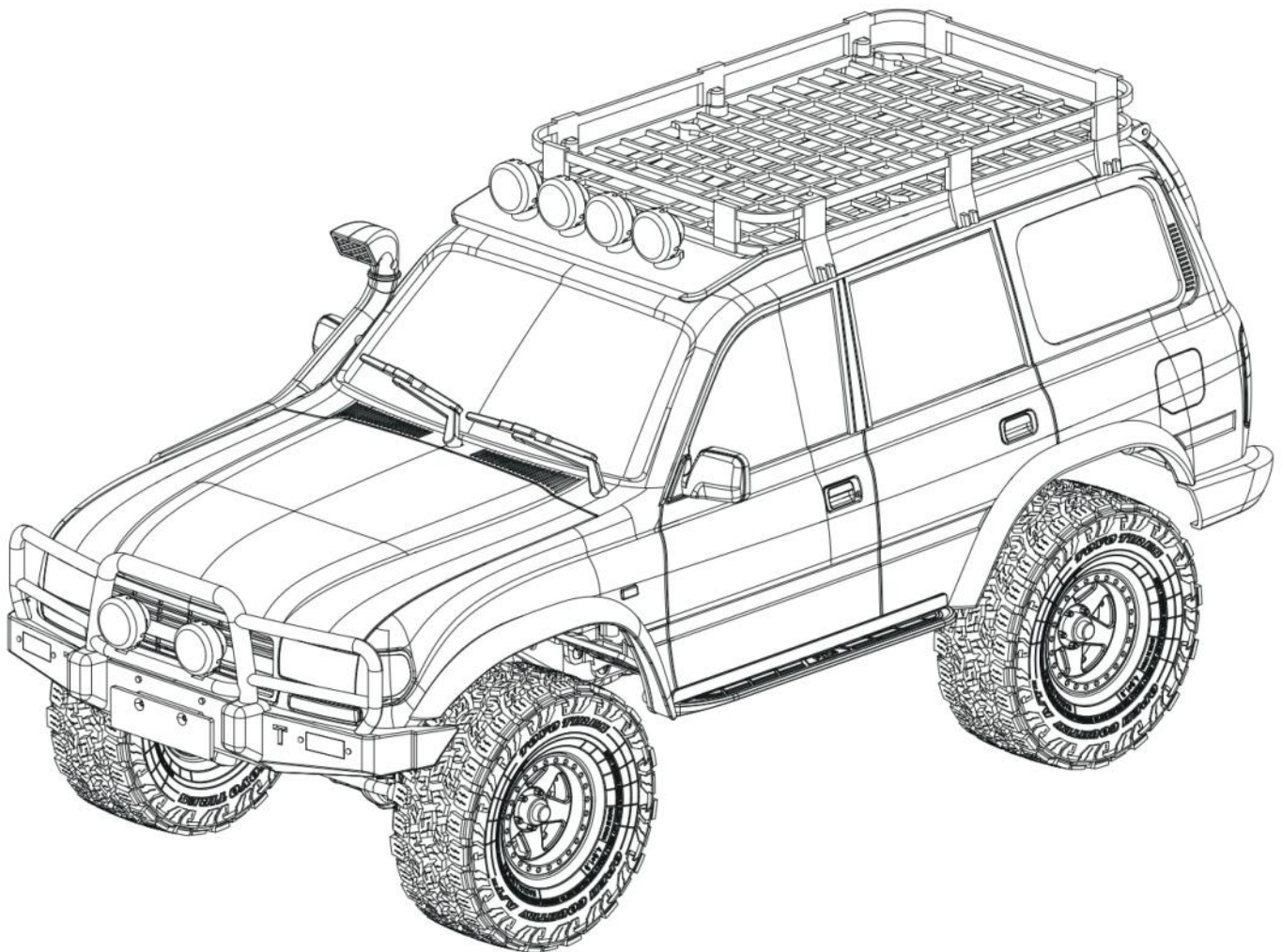

**FCX10**  
**BRUSHLESS VERSION**

MAN-G0317

*Instruction Manual*  
操作手册

## Disclaimer and Warning 免责声明与警告

Thank you for purchasing our product. This product is composed of precision components and is not a toy. It is not suitable for use by individuals under the age of 14. Please do not allow children to come into contact with this product. Exercise extra caution when operating this product in the presence of children. This product is a remote-controlled model and will provide a smooth and easy operating experience when the power is functioning correctly, and all components are undamaged. Visit [www.fmshobby.com](http://www.fmshobby.com) to access the latest product manual and related supplementary instructions and warnings. We reserve the right to update this manual. If there are updates to this manual, they will not be notified separately.

Before using the product, please carefully read this product manual to understand your legal rights, responsibilities, and safety instructions. Failure to do so may result in property damage, safety incidents, and personal safety risks. Once you use this product, it is considered that you have understood, accepted, and agreed to all the terms and content of this manual. Users are responsible for their actions and all consequences arising from them. Users commit to using this product only for legitimate purposes and agree to all the terms and content in this manual as well as any relevant policies or guidelines that our company may establish. Our company and distributors are not liable for any losses caused by users not following the product manual. In compliance with laws and regulations, our company reserves the final interpretation of this manual. Our company has the right to update, revise, or terminate these terms without prior notice.

This manual is intended to assist you in correctly operating, maintaining, and repairing the vehicle. Since most of the components involved in this product are unique parts, please keep this manual for future reference.

感谢您购买我们的产品。本产品由精密部件组成，并非玩具，因此不适合 14 岁以下的人士使用。请勿让儿童接触本产品。在有儿童出现的场景操作时请务必特别小心注意。本产品是一款遥控模型产品，在电源正常工作及各部件未损坏的情况下将提供轻松自如的操作体验。请访问以下网址[www.fmshobby.com](http://www.fmshobby.com)获取最新的产品手册及相关附加说明与警告。我司保留更新本手册的权力。本手册如有更新，恕不另行通知。

请务必在使用产品之前仔细阅读本产品手册，了解您的合法权益、责任和安全说明，否则，可能带来财产损失、安全事故和人身安全隐患。一旦使用本产品，即视为您已理解、认可和接受本手册全部条款和内容。使用者承诺对自己的行为及因此而产生的所有后果负责。使用者承诺仅出于正当目的使用本产品，并且同意本手册内的全部条款和内容及我司可能制定的任何相关政策或者准则。我司及分销商不承担因用户未按产品手册使用产品所引发的一切损失。在遵从法律法规的情况下，我司享有对本手册的最终解释权。我司有权在不事先通知的情况下，对本条款进行更新改版或终止。

本手册旨在帮助您正确操作、维护和修理车辆。由于本品所涉部件多数为特有部件，请保留本手册作为未来参考之用。

## Safety, precautions and warnings 安全、预防措施及警告

- Replace damaged components with original factory-parts. Pay special attention to the polarity of all vehicle wiring.
- Use common sense when selecting the environment to operate your vehicle. Do not operate near power cables, cellular/radio towers, deep water or unstable terrain. The operator is solely responsible for their actions.
- The product is composed of precision electrical components. It is critical to keep the product away from moisture and other contaminants.
- Always check the radio range of the vehicle prior to operation in order to prevent radio loss or interference.
- Operate this product within your ability. If the vehicle is dangerous to retrieve, it never worth the risk.
- Always turn on the transmitter before connecting the battery on the model. When turning off the model, always disconnect the battery first, and then turn off the transmitter. If this order is reversed, the model may become uncontrollable and cause serious damage.
- Never allow transmitter batteries to run low as it may cause loss of vehicle control.
- Plastics on the vehicle are susceptible to damage or deformation due to extreme heat and cold climate. Do not store the model near any source of heat such as oven or heater. Store the model indoors, in a climate-controlled, room temperature environment.

- 请使用原厂部件更换损坏的部件。特别注意所有车辆接线的正负极。
- 务必选择合适的环境操作遥控模型，所选环境需远离电缆、无线电塔、深水及不稳定地形。本品操作者对其行为全权负责。
- 本品由精密电子部件构成。请勿将本品暴露于潮湿的环境或者其他污染物中。
- 确保每次操作前检查车辆的无线接收范围，以防止无线信号丢失或受干扰。

- 在您的能力范围内操作此产品。在任何时候，如果车辆操作有危险，则绝对不值得冒险。
- 通电方式：务必先开遥控器再将车子通电。断电方式：务必先将车子断电再关遥控器。以上顺序如逆转，则可能引起遥控模型失控，导致人身伤害或财产损失。
- 遥控器电池低电时，请勿操作模型车，以免出现失控。
- 模型产品上的塑胶件容易因极冷或极热气候出现变形或损坏的状况。所以请将模型产品存放在气候受控的室温环境中，切勿靠近任何热源，如烤箱或加热器等。

This product is not a toy! (14+) Recommended for ages 14 and up. Adult supervision required for ages under 14 years old. Contains small parts, keep out of reach of children 3 years of age and younger.

使用前请仔细阅读本手册。我们不对任何故意损坏或不当使用负责。这个产品不是玩具！建议14岁及以上者使用。14岁以下的用户，需要在成年人监督下使用。本产品部分包含小零件，请务必保证3岁及以下儿童不能接触本产品。

## Safety symbols 安全符号

Pay close attention to the following symbols and their meanings. Failure to follow these warnings could cause damage, injury or death.

仔细阅读以下符号及其相关说明，如不按照以下指引进行操作，可能会导致设备损坏或人员伤亡。

 <b>Danger</b> 危险	<b>Not following these instructions may lead to serious injuries or death.</b> 如果使用者不按照说明方法操作，有可能导致操作者或他人受到严重受伤，甚至遭受生命危险。
 <b>Warning</b> 危险	<b>Not following these instructions may lead to major injuries.</b> 如果使用者不按照说明方法操作，有可能导致操作者或他人受到轻微伤害。
 <b>Caution</b> 危险	<b>Not following these instructions may lead to minor injuries.</b> 如果使用者不按照说明方法操作，可能导致操作者或他人轻微伤害。

## Safety guide 安全信息

### Prohibited 禁止

- Do not use the product at night or in bad weather like rain or thunderstorm. It can cause erratic operation or loss of control.
- Do not use the product when visibility is limited.
- Do not use the product on rain or snow days. Any exposure to moisture (water or snow) may cause erratic operation or loss of control.
- Interference may cause loss of control. To ensure the safety of you and others, do not operate in the following places:
  1. Near any site where other radio control activity may occur
  2. Near power lines or communication broadcasting antennas
  3. Near people or roads
  4. On any body of water when passenger boats are present
- Do not use this product when you are tired, uncomfortable, or under the influence of alcohol or drugs. Doing so may cause serious injury to yourself or others.
- The 2.4GHz radio band is limited to line of sight. Always keep your model in sight as a large object can block the RF signal and lead to loss of control.
- Do not touch any part of the model that may generate heat during operation, or immediately after use. The engine, motor or speed control, may be very hot and can cause serious burns.
- Please ensure that the magnetic connectors on the chassis and car shell do not come into contact with metal objects to prevent any potential electronic short circuits!

- 请不要在夜晚或雷雨天气使用本产品，恶劣的天气环境有可能导致遥控设备失灵。

- 请不要在能见度有限的情况下使用本产品。
- 请不要在雨雪或有水的地方使用本产品。如果有液体进入到系统内部，可能会导致运行不稳定或失灵。
- 信号干扰可能导致设备失控。为保证您和他人安全，请不要在以下地点使用本产品：
  - 1、通信基站附近或其他无线电活跃的地方
  - 2、人多的地方或道路附近
  - 3、水域附近
  - 4、高压电线或通信广播天线附近
- 当您感到疲倦、不舒服，或在摄入酒精或服食导致麻醉或兴奋的药物后，不要操作本产品。否则可能对自己或他人造成严重的伤害。
- 2.4GHz无线电波段完全不同于之前所使用的低频无线电波段。使用时请确保模型产品在您的视线范围内，大的障碍物将会阻断无线电频率信号从而导致遥控失灵模型失控。
- 请勿在操作过程中或使用后立即触摸模型可能产生热量的任何部分。发动机、电机或速度控制器可能非常热，并可能导致严重烧伤。
- 请务必确保底盘和车壳上的磁体结合件不与金属物品接触，以免引发电子短路！

## ! Mandatory 强制

- Misuse of this product may lead to serious injury or death. To ensure the safety of you and your equipment, read this manual and follow the instructions.
- Make sure the product is properly installed in your model. Failure to do so may result in serious injury.v
- Make sure to disconnect the receiver battery before turning off the transmitter. Failure to do so may lead to unintended operation and cause an accident.
- Ensure that all servos operate in the correct direction. If not, adjust the direction first.
- Make sure the model stays within the systems maximum range to prevent loss of control.
- 遥控设备使用不恰当可能导致操作者或他人严重受伤，甚至死亡。为保证您和设备的安全，请仔细阅读使用说明书并按照要求进行操作。
- 使用前必须确保本产品与模型安装正确，否则可能导致模型发生严重损坏。
- 关闭时，请务必先关闭接收机电源，然后关闭发射机。如果关闭发射机电源时接收机仍然在工作，将有可能导致遥控设备失控或者引擎继续工作而引发事故。
- 操控时，请先确认模型所有舵机的动作方向与操控方向一致。如果不一致，请调整好正确的方向。
- 当遥控距离较远时，有发生失控的可能，请适当缩短遥控距离。

# Certifications

# 认证相关

## DoC Declaration

Hereby, [ShenZhen FLYSKY Technology Co., Ltd.] declares that the Radio Equipment[FS-FMS-MG6-BS&FS-FMS-MG6-BS&FS-FMS-R6D-ESC-BS] is in compliance with RED 2014/53/EU.  
 The full text of the EU DoC is available at the following internet address: [www.flyskytech.com/info\\_detail/10.html](http://www.flyskytech.com/info_detail/10.html)

ETSI EN 301 489-1 V2.2.3 (2019-11)	BS EN 62479:2010
ETSI EN 301 489-17 V3.2.4 (2020-09)	BS EN IEC 62368-1:2020+A11:2020
ETSI EN 300 328 V2.2.2 (2019-07)	

## CE Warning

The antenna(s) used for this transmitter must be installed to provide a separation distance of at least 20 cm from all persons and must not be co-located or operating in conjunction with any other transmitter. End-users and installers must be provided with antenna installation instructions and transmitter operating conditions for satisfying RF exposure compliance.

## FCC Statement

This equipment has been tested and found to comply with the limits for a Class B digital device pursuant to part 15 of the FCC rules. These limits are designed to provide reasonable protection against harmful interference in a residential installation. This equipment generates, uses and can radiate radio frequency energy and, if not installed and used in accordance with the instructions, may cause harmful interference to radio communications. However, there is no guarantee that interference will not occur in a particular installation. If this equipment does cause harmful interference to radio or television reception, which can be determined by turning the equipment off and on, the user is encouraged to try to correct the interference by one or more of the following measures:

- Reorient or relocate the receiving antenna.
- Increase the separation between the equipment and receiver.
- Connect the equipment into an outlet on a circuit different from that to which the receiver is connected.
- Consult the dealer or an experienced radio/TV technician for help.

To assure continued compliance, any changes or modifications not expressly approved by the party responsible for compliance could void the user's authority to operate this equipment.

This equipment complies with Part 15 of the FCC Rules. Operation is subject to the following two conditions:

- (1) This device may not cause harmful interference.
- (2) This device must accept any interference received, including interference that may cause undesired operation.

Caution!

The manufacturer is not responsible for any radio or TV interference caused by unauthorized modifications to this equipment. Such modifications could void the user authority to operate the equipment.

1. The antenna(s) used for this transmitter must be installed to provide a separation distance of at least 20 cm from all persons and must not be co-located or operating in conjunction with any other transmitter. End-users and installers must be provided with antenna installation instructions and transmitter operating conditions for satisfying RF exposure compliance.

2. Move all your channels to the desired position.
3. Select [All channels] and then [Yes] in the confirmation box.

## Environmentally friendly disposal

Old electrical appliances must not be disposed of together with the residual waste, but have to be disposed of separately. The disposal at the communal collecting point via private persons is for free. The owner of old appliances is responsible to bring the appliances to these collecting points or to similar collection points. With this little personal effort, you contribute to recycle valuable raw materials and the treatment of toxic substances.

**CAUTION**  
**RISK OF EXPLOSION IF BATTERY IS REPLACED BY AN INCORRECT TYPE.**  
**DISPOSE OF USED BATTERIES ACCORDING TO THE INSTRUCTIONS.**

**FS-MG11-BS CE,FCCID:2A2UNMG1100**  
**FS-FMS-R11D-BS FCCID:2A2UNR11P01**



**CAUTION**  
 Risk of explosion if the battery is replaced an incorrect disposal of a battery into fire or a hot oven, or mechanically crushing or cutting of a battery, that can result in an explosion; leaving a battery in an extremely high temperature surrounding environment that can result in an explosion or the leakage of flammable liquid or gas; battery subjected to extremely low air pressure that may result in an explosion or the leakage of flammable liquid or gas.

## Background 产品背景

### Toyota Land Cruiser LC80: Born to Conquer

The Toyota Land Cruiser LC80 stands as a legendary off-road icon, officially launched in 1990. But its roots trace back nearly a decade earlier—into the early 1980s—when Toyota initiated the ambitious mission to replace the aging LC60 series with something bolder, tougher, and more refined.

At the heart of the LC80's development was a formidable challenge: blend world-class off-road capability with enhanced comfort, safety, and drivability. Toyota engineers sought to create a vehicle that could handle punishing terrain while remaining stable, reliable, and comfortable enough for everyday use.

To achieve this, Toyota deployed cutting-edge tools for the time—such as CAD design and numerical simulation—and conducted extensive field testing across harsh, real-world environments. The result was a breakthrough: a full-size SUV engineered to dominate trails, deserts, and mountains with unwavering confidence, while offering improved ride quality and interior refinement.

Upon release, the LC80 received international acclaim. It became a cornerstone of Toyota's off-road legacy and a trusted name among overland adventurers, humanitarian organizations, and off-road enthusiasts worldwide. Its rugged frame, robust drivetrain, and enduring reliability helped set a new standard—and its success paved the way for future Land Cruiser generations.

More than just a vehicle, the LC80 represents a turning point in Toyota's off-road engineering journey—where durability met innovation, and tradition evolved with technology.

丰田陆地巡洋舰LC80是在20世纪90年代初期研发的一款大型越野车。其研发背景可以追溯到20世纪80年代初期。80年代初，丰田公司决定开发一款全新的越野车型，以取代其LC60系列越野车。在研发过程中，丰田公司面临着很多挑战。首先，丰田需要在保持越野性能的同时提高车辆的舒适性和安全性。其次，丰田需要确保LC80在适应不同地形和环境的同时，仍然能够保持稳定和可靠性。

为了克服这些挑战，丰田公司进行了大量的研发和测试工作。他们采用了现代化的CAD技术和数值模拟技术，为车辆的设计和开发提供了有效的工具。此外，丰田还进行了大量的越野测试，以确保车辆在各种路面和环境下表现出色。

最终，丰田LC80在1990年正式发布，并受到了广泛的认可和好评，成为了丰田越野车系列中的经典之作，被认为是越野车市场上的领导者之一。同时，丰田公司也通过LC80的研发和生产积累了丰富的越野车制造经验，为后来的车型开发奠定了坚实的基础。

## About Model 产品介绍

Authorized by Toyota, this 1/10 Land Cruiser 80 from FMS Models adopts FCX10 simulation crawler chassis, which faithfully restores the off-road performance of the original car.

In terms of appearance, FMS still maintains a consistently high standard. In order to ensure the durability, the car body is used in PC material. In the case, the car is equipped with mirrors and waders. Through the transparent window you can see a high degree of simulation of the figure, the exquisite dashboard and cockpit interior. The roof is equipped with a luggage rack and four offroad lights. There is a climbing ladder at the rear. The vehicle comes pre-installed with headlights, front turn signals, side turn signals, rear turn signals, reverse lights, and other lighting components. The car shell uses a magnetic interface to draw power from the chassis, allowing the lights of the entire vehicle to be activated with a single button on the remote control. Additionally, we also have pre-installed fenders to keep mud from spilling onto the body and chassis. We have also co-branded with ovrmag.com to jointly launch a fully licensed edition. This edition adds KC vintage and modern style lamp shades, and is equipped with HDR wheels and TOYO Open Country A/T III tires.

The whole chassis adopts the mainstream middle front power layout, four-link suspension; In order to better restore the real car, we cancel the portal axles, but the larger tires can still provide enough ground clearance and climbing ability. The mid-front motor and transmission, as an integral unit, have a lower center of gravity compared to similar products, resulting in a lower rolling center and reduced likelihood of rollovers. Meanwhile, There is a metal-gear waterproof servos placed in the side of battery compartment, responsible for switching high and low speeds.

In order to maximize the performance, FMS use a higher class brushless power system. Compared to brushed combo, 50A independent ESC(6V/3A BEC output) and 3541 outer runner brushless motor provide an exceptionally delicate linear control experience, allowing you to feel the vehicle to snail-like low uniform speed crawling. At the same time, the outer rotor structure has its own good dynamic balancing characteristics, which reduces the end effect of the stator winding to improve running performance.

In terms of convenience of daily maintenance, FMS also gives you a good consideration. The battery compartment can be flipped back or "quick release". All the electronic equipment is concentrated in the middle of the chassis, so it is very convenient for daily maintenance or removal and replacement. Thanks to our R&D capabilities, we have innovatively designed a knob-type quick release structure (this structure has been patented), and at the same time, the power and signal cables of the lights are perfectly integrated with the magnetic module.

Except for the adventurous heart, you don't need to prepare any other things. FMS will take off-road journey for you!

由丰田汽车公司授权，FMS模型出品的这款1/10模型车Land Cruiser 80，采用FCX10仿真攀爬底盘，忠实还原了原车的越野性能。

在外观仿真度方面FMS仍旧保持一贯的高水准，车壳使用PC吸塑软壳，在保证车身耐用度的情况下，车上装有后视镜和涉水器，透过透明车窗可以看到高仿真度的人偶、精美的仪表盘以及座舱内饰，车顶配备有行李架和四个橘黄色的越野探照灯，在尾部同时标配爬梯。出厂大灯，前转向灯，两侧转向灯，后转向灯，倒车灯等均已预装完毕，车壳采用磁吸接口从底盘取电，遥控器一键唤醒全车灯光表达；此外，我们还预装了挡泥板，可以防止泥土溅到车身及底盘上。我们还与国外著名杂志ovrmag.com联名，共同推出全授权版本，增加KC复古款和现代款灯罩，配备HDR轮毂和TOYO opencountry A/T III轮胎。

整个底盘采用主流的中前置动力布局，四连杆悬挂，为了更好的还原实车，没有使用时下流行的门桥，但更大直径的轮胎依然可以提供足够的离地间隙和攀爬能力，而中前置电机和变速箱作为一个整体，重心比同级产品更低，滚动重心也更低，更不易侧翻。同时电池仓一侧配备了金属防溅水舵机，负责高低速档位切换。

为了将性能发挥到极致，在电子设备上毫不吝啬。我们使用了采用无刷动力组，50A的独立无刷电调（BEC输出6V/3A）搭配3541外转子无刷电机，相对于有刷套装，有着异常细腻的线性控制体验，让你尽情感受车辆以蜗牛般的低匀速爬行。

在日常检修便利性方面，FMS同样为您考虑周到，电池仓可向后翻起或“快拆”，所有电子设备都集中在车辆中部，日常检修维护或者拆换都非常方便。得益于强大的研发实力，我们创新性地设计了旋钮式快拆结构（此结构已获发明专利），同时将灯组的供电线及信号线完美地与磁吸模块融合在一起。

除了准备一颗渴望冒险的心，您无需再准备其它任何配件，FMS为您开启越野之旅！

## Features 特点

### ● Toyota & OVR Officially Licensed Body

Realistically modeled Land Cruiser LC80 with full Toyota licensing and exclusive OVRmag co-branding.

### ● Highly Detailed Interior

Includes molded dashboard, steering wheel, cockpit elements, and scale driver figure.

### ● Full LED Lighting System (Pre-Installed)

Headlights, turn signals (front, side, and rear), reverse lights, and more—magnetically activated via chassis connection.

### ● HDR Licensed Off-Road Wheels & TOYO Open Country A/T III Tires

Authentic scale performance wheels and aggressive all-terrain tires for realistic trail stance.

### ● KC Light Kit (Included)

Includes both vintage and modern KC-style lamp shades and KC logo stickers (not factory-installed).

### ● Brushless Power System

3541 KV1200 Outrunner Brushless Motor

50A Brushless ESC with 6V/3A BEC

Top speed up to 20 km/h

Smooth, snail-speed crawling performance

### ● Selectable High & Low Speed Transmission

Two-speed gearbox for scale realism and superior terrain adaptability, controlled remotely.

### ● Solid Axle Suspension

Authentic solid axles front and rear—no portals—for true scale accuracy and rock crawling articulation.

### ● RS Version with Upgraded Chassis

Premium-grade "RS" spec version with enhanced durability and performance tuning.

### ● Quick-Release Magnetic Body System (Patented)

Innovative magnetic interface integrates power and signal; knob-lock chassis allows fast access.

### ● Metal Height-Adjustable Oil Shocks

Tunable ride height and damping for trail or technical terrain.

### ● All-Metal Gear Train

Precision-cut metal gears for reliability and long-term durability.

### ● Full Ball Bearings

Smooth, efficient drivetrain with reduced friction and longer component life.

- 丰田& OVR 授权像真车壳
- 仿真内饰+人偶
- 丰富灯光效果
- HDR轮毂+TOYO OpenCountry AT III轮胎
- KC灯罩 (含复古款和现代款灯罩, KC灯个性贴纸, 出厂不预装)
- 无刷动力组 (3541-KV1200外转子无刷电机, 50A无刷电调, 速度可达20km/h)
- 高低速换挡, 可攀爬, 可越野, 双倍驾驶乐趣

- 仿真直桥设计
- RS组装完成品
- 专利快拆结构+磁吸灯控
- 金属绞牙避震器
- 全车金属齿轮
- 全车滚珠轴承

## Specification 产品参数

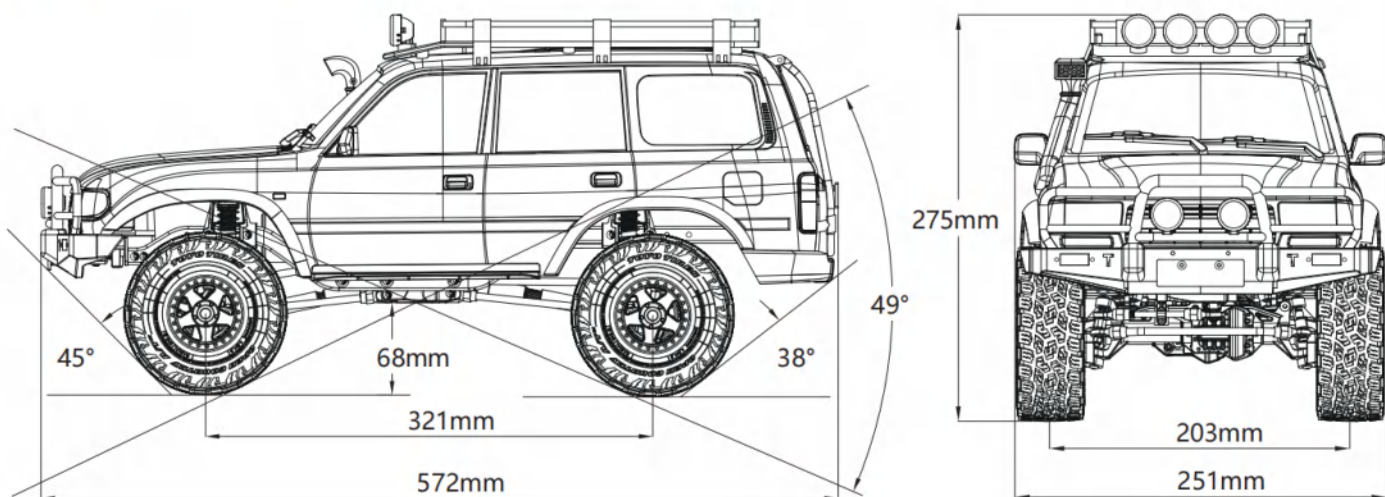

Version	RS	配置	RS
Transmitter	MG11	发射型号	MG11
Receiver	R11D-BS	接收型号	R11D-BS
Light Control	DB01 PWM Input	灯控型号	DB01 PWM INPUT
Recommend Battery	2S 5000mAh, 3S 5000mAh	推荐电池	2S 5000mAh, 3S 5000mAh
Brushless Motor	3541-KV1200	无刷电机	3541-KV1200外转
Motor Gear Pinion	10T	马达齿齿数	10T
Motor Gear Pitch	0.8M	马达齿模数	0.8M
Spur Gear Pinion	47T	正齿轮齿数	47T
Spur Gear Pitch	0.8M	正齿轮模数	0.8M
ESC	SL50A 2-3S brushless	电调	SL50A 2-3S 无刷电调
Steering Servo	25KG Metal Gear 25.5Kg.cm*1 (waterproof)	转向舵机	25KG 金属齿 25.5Kg.cm 防水*1
Shift Servo	13g metal gear servo*1	换挡舵机	13g金属齿舵机*1
Product Size	572*251*275mm	整车尺寸 (长宽高)	572x251x275mm (带射灯)
Wheelbase	321mm	轴距	321mm
Tread	203mm	轮距	203mm
Approach Angle	45°	接近角	45°
Departure Angle	38°	离去角	38°

Breakover Angle	55°	纵向通过角	55°
Ground Clearance	68mm	离地距离	68mm
Steering Type	Front 2WS	转向	前2WS
Maximum steering angle	49°	最大转向角	49°
Maximum Climbing Angle	60°(artificial turf)	最大爬坡角度	60°(人造草皮)
Tire Size	116*45mm	轮胎 (直径和宽度)	116 X 45mm
Wheelhub Size	54*27.4mm	轮毂 (直径和宽度)	54 X 27.4mm
Wheelhub Adaptor Size	12mm	轮毂接合器尺寸	12mm
Bearing	Full Bearing	轴承	全车轴承
Drive System	4WD	驱动形式	四驱
Waterproof Class	Splash-proof	是否防水	防溅水
Battery Compartment Size	140*47*40mm / 170*47*40mm (without receiver)	电池舱尺寸	140*47*40mm/170*47*40mm (除去接收机)
Maximum Speed	20km/h	最大速度	20km/h
Endurance Reference	30mins (3S 5000mAh 35C)	续航时间	30分钟 (3S 5000mAh 35C)
Maximum Control Distance	150m in clear space	最大遥控距离	≤150米

## Transmitter Intruction

## 发射机概览

### Transmitter instruction 发射机介绍

The FS-MG11-BS is a 11-channel transmitter that adopts the 2.4GHz 2A-BS Automatic Frequency Hopping Digital System. The transmitter is lightweight and compact in design, comfortable and ergonomic. The transimtter supports ESC parameters setting and compatible with variety of car models.

FS-MG11-BS 是一款使用 2.4GHz2A-BS 版自动跳频数字系统的发射机，输出十一通道，外观轻巧，手感舒适，符合人体工程学，支持通过发射机设置电调参数，适配车模型使用。

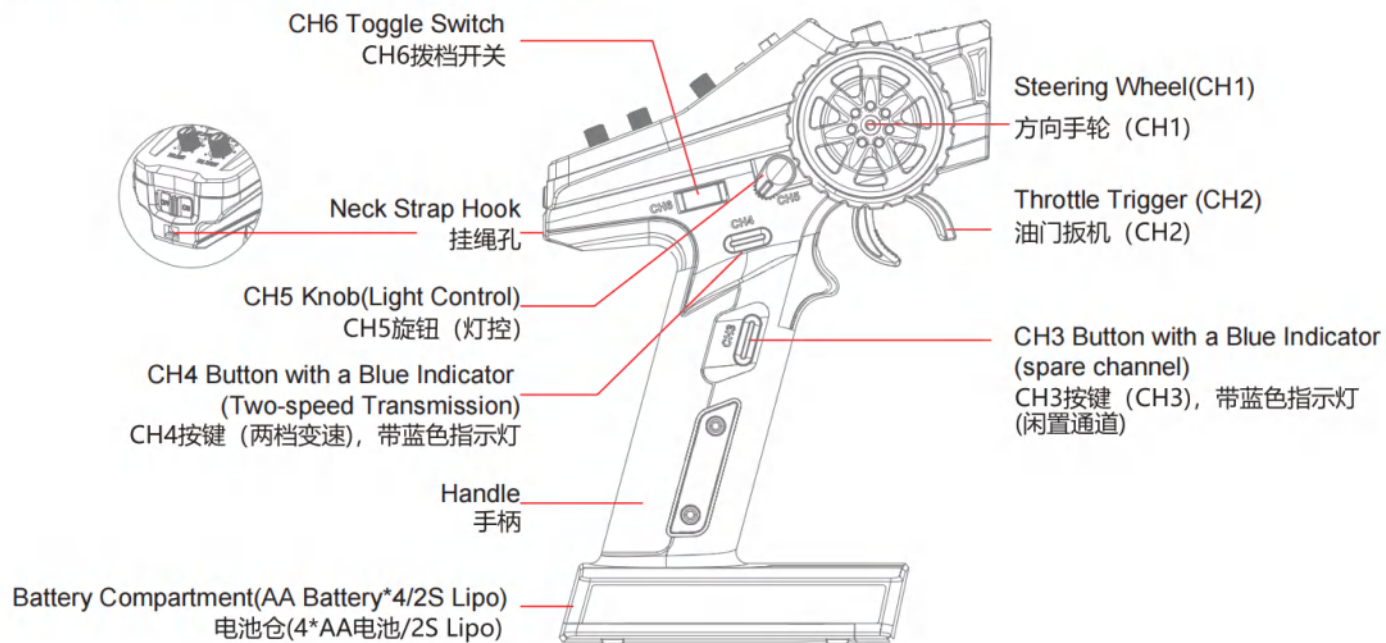

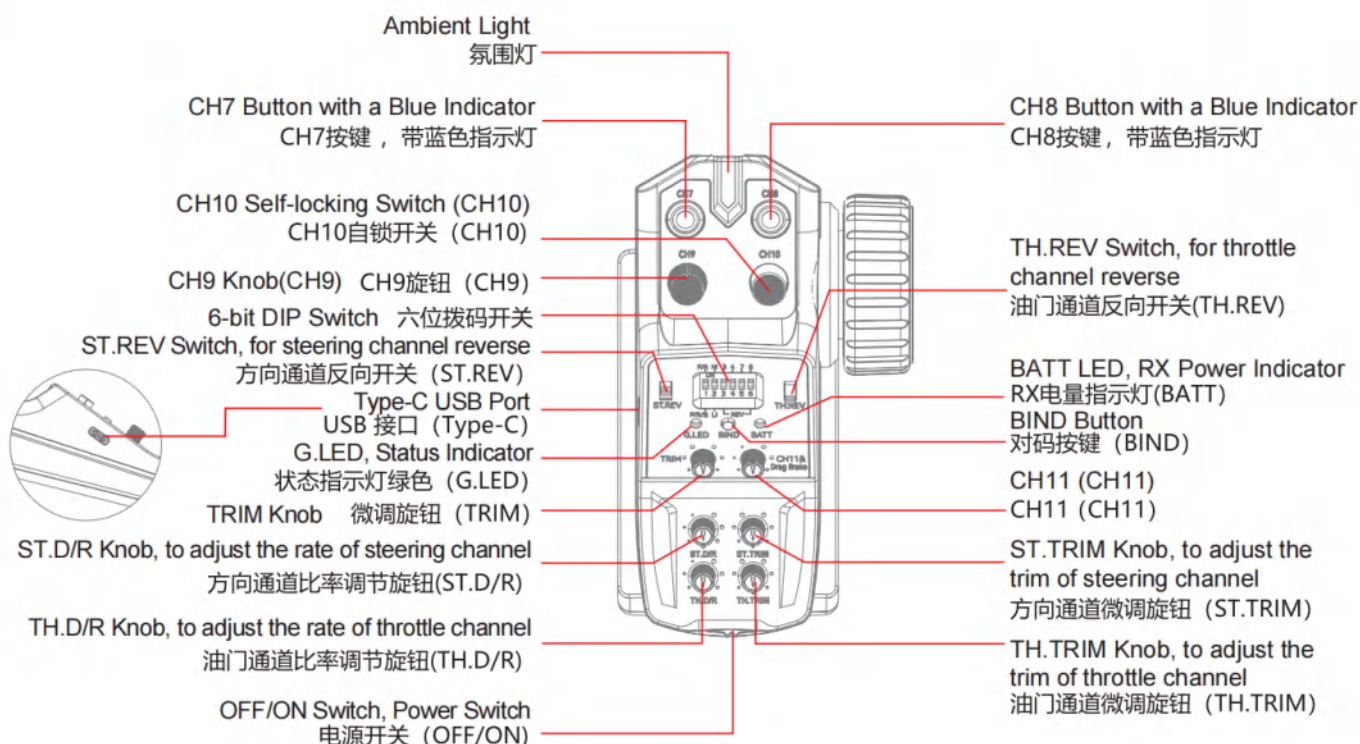

## Getting Started

## 使用前准备

Before operation, install the battery and connect the system as instructed below.

开始操作前, 请按照本章的顺序和指引安装电池、连接设备。

### Transmitter Antenna 发射机天线

The transmitter has a built-in antenna. When the transmitter starts to work, the antenna automatically operate, without additional operations.

本发射机天线为内置天线, 发射机开始工作, 天线自动工作。

### Receiver and Servo Installation 接收机与舵机安装

Make sure that the receiver is mounted in an appropriate location within the model, to ensure a stable signal, maximum range and to mitigate external interference, follow these guidelines:

Pay attention to the following when installing the receiver:

1. Make sure the receiver is not installed near motors or sources of electrical noise.
2. Keep the receiver's antenna away from conductive materials such as carbon or metal. To ensure normal function, make sure there is a gap of at least 1cm between the antenna and the conductive material.







请结合相应模型的结构选择合适的位置安装接收机, 同时为了确保接收机的性能和遥控距离的稳定, 并防止外界干扰, 请注意以下操作事项:

安装过程中请注意以下事项:

1. 确保接收机安装在远离电机, 或电子噪声过多的区域。
2. 接收机天线需远离导电材料, 例如金属棒和碳纤维物质。为了避免影响正常工作, 请确保接收机和导电材料之间至少有 1 厘米以上的距离。

 <b>Caution</b> 注意	To prevent damage do not power on the receiver during installation. 准备过程中, 请勿连接接收机电源, 避免造成不必要的损失
--	---

## Transmitter Battery Installation 发射机电池安装

 <b>Danger</b> 注意	Only use specified battery (X4 AA batteries). 仅使用厂家指定的电池。
 <b>Danger</b> 注意	Do not open, disassemble, or attempt to repair the battery. 请勿打开、拆卸或自行维修电池。
 <b>Danger</b> 注意	Do not crush/puncture the battery, or short the external contacts. 请勿挤压、刺穿或接触电池的金属端子。
 <b>Danger</b> 注意	Do not expose to excessive heat or liquids. 准请勿将电池置于高温环境或液体中。
 <b>Danger</b> 注意	Do not drop the battery or expose to strong shocks or vibrations. 请注意防止电池跌落、碰撞或振动。
 <b>Danger</b> 注意	Always store the battery in a cool, dry place. 请将电池存放在干燥阴凉的环境中。
 <b>Danger</b> 注意	Do not use the battery if damaged. 如果电池损坏，请立即停止使用。

### Installing the AA Battery

Follow the steps below to install the AA batteries:

1. Open the battery compartment cover as illustrated.
2. Insert 4 fully-charged AA batteries into the compartment. Make sure that the batteries are well set according to the polarities marked on the battery compartment.
3. Replace battery compartment cover.

### Installing the LiPo Battery

Follow the steps below to install the LiPo battery:

1. Open the battery compartment cover.
2. Insert 2S fully-charged LiPo battery into the compartment.
3. Plug the cable of LiPo battery into the JST Jack. Make sure to connect correctly according to the polarities marked on the battery compartment.
4. Replace battery compartment cover. Be careful not to pinch the cable.

### AA 电池安装

请按照以下步骤安装 AA 电池:

- 1、打开电池仓盖(如图所示);
- 2、将 4 颗电量充足的电池按标注的极性方向装入电池仓内;
- 3、盖好电池仓盖。

### LiPo 锂电池安装

请按照以下步骤安装锂电池:

- 1、打开电池仓盖;
- 2、将 2S 电量充足的锂电池放入电池仓内;
- 3、将电池连接线接入 JST接口，确保正确连接正负极;
- 4、盖好电池仓盖，注意不要夹到电池连接线。



After setting up, follow the instructions below to operate the system.

准备操作完成后，您可以按照本章指引开始使用本产品。

## Power On 开机

Follow the steps below to turn on the transmitter:

1. Check to make sure that the batteries are fully charged and installed correctly.
2. Toggle the Power Switch to the ON position. The G.LED will be solid on, both the ambient light and the BATT LED will be on for 3 seconds, and then will be off.

**Note:** For safety, always power on the transmitter before the receiver.

请按照以下步骤进行开机：

- 1、检查系统状态，确保电池电量充足且安装正确；
- 2、将电源开关拨到 [ON] 位置，G.LED 指示灯常亮，氛围灯和 BATT 指示灯亮 3 秒后灭。

**注：**为保障模型及人员安全，使用时请先打开发射机再给接收机通电。



**Warning**  
警告

Operate with caution in order to avoid damage or injury.  
此时系统已启动，请谨慎操作，否则可能导致产品损坏或人员伤亡。

## LED Indicator LED 指示

The G.LED of the transmitter is used to indicate the functional status of the transmitter; The ambient light and BATT LED are used to indicate the power status of the transmitter and the power status of the receiver, the details are as follows.

1. G.LED: The green status indicator
  - When the transmitter is in binding state, the G.LED will flash rapidly.
  - When the transmitter voltage is low, the G.LED will flash slowly.
  - When the transmitter is in idle alarm state, the G.LED will be in gradual light state.
  - When the transmitter is in end point adjustment status, the G.LED will work in two-flash-one-off state.
2. BATT Indicator: The battery power indicator for the transmitter or the 2-in-1 receiver
  - When the battery power is high, the BATT LED will be solid on in green.
  - When the battery power is medium, the BATT LED will be solid on in yellow.
  - When the battery power is low, the BATT LED will be solid on in red.
  - When the battery power is ultra low, the BATT LED will flash slowly in red.

**Note:** In three seconds after the power-on of the transmitter, the ambient light and BATT LED indicate the transmitter battery power status. When the transmitter is powered on for 3 seconds, the transmitter battery power status is indicated in case of binding a standard receiver. The receiver battery power status is indicated in case of binding 2-in-1 receiver.

- When the transmitter does not receive the return signal, the ambient light and BATT LED will be off.
- When the receiver is de-bound, the ambient light and BATT LED will maintain in the state when the receiver is de-binding.

本发射机的 G.LED 用于指示发射机功能状态；氛围灯与 BATT 指示灯用于指示发射机电池电量状态及接收机回传的电池电量状态，具体如下：

### 1、G.LED:绿色状态指示灯

快闪：对码状态    • 慢闪：电压低    • 呼吸灯：闲置状态    二闪一灭：舵量设置

### 2、氛围灯；BATT：发射机/二合一接收机电池电量状态指示灯

• 绿色常亮：电压高    • 黄色常亮：电压中    • 红色常亮：电压低    • 红色慢闪：电压超低

**注：**发射机开机后前3秒，氛围灯和 BATT 指示灯指示发射机电池电量状态；当发射机开机3秒后，若对码标准接收机则指示发射机电池电量状态；若对码二合一接收机，则指示接收机电池电量状态：

- 未收到接收机回传信号时，氛围灯和 BATT 指示灯灭
- 接收机掉码时，氛围灯和 BATT 指示灯则保持掉码时状态

## Binding 对码

The transmitter and the receiver have been pre-bound before delivery. If you are going to use another receiver, follow the steps below to rebind. The transmitter supports two-way binding, the steps are as following:

1. Turn on the transmitter while holding the BIND button, then the transmitter will enter the binding mode. At this time, the G.LED will flash quickly. Once in binding mode, release the BIND button.
2. Turn on the receiver, and it will wait for 1 second for connection. If without connection, the receiver will enter the binding mode automatically. At this time, the receiver LED will be flashing fast.
3. Once the binding is successful, the receiver LED and the G.LED of the transmitter will be solid on.
4. Verify that the transmitter and the receiver are working properly. If you need to re-bind, repeat the above steps.

### Notes:

1. Applicable to the FS-MG11-BS transmitter and the FS-R11D-BS receiver.
2. The FS-MG11-BS transmitter complies with the 2A-BS protocol and is only compatible with receivers conforming to this protocol.
3. Different receivers have different bind procedures. For more information, visit the FLYSKY website for manuals and other related information.

本发射机和接收机在出厂前已对码成功。若需使用其他接收机，请按照如下步骤进行对码。本发射机支持双向对码，对码步骤如下：

1. 将发射机按住对码按键(BIND)开机即进入对码状态，此时 G.LED 指示灯快闪，松开对码按键；
2. 接收机上电等待 1秒没有连接即自动进入对码状态，此时接收机 LED 快闪；
3. 对码成功后，接收机 LED 指示灯及发射机 G.LED 指示灯常亮；
4. 检查发射机、接收机是否正常工作。如需重新对码，请重复以上步骤。

### 注：

1. 此对码步骤仅适用于 FS-MG11-BS 发射机与 FS-R11D-BS 接收机对码；
2. FS-MG11-BS 发射机采用 2A-BS 协议，只兼容该协议的接收机。
3. 不同的接收机对码方式不同，具体对码方式请访问 FLYSKY 官网查询接收机说明书或其他相关资料。

## Stick Calibration 摇杆校准

Use this function to correct for the mechanical deviation of the throttle trigger, steering wheel and CH5 knob, for example, deviation occurred in the self-centering or maximum minimum travel, the steps are as following:

1. Turn and hold the steering wheel clockwise to the max travel point and push the throttle trigger forwards as far as possible, and at the same time turn on the transmitter, the transmitter will be in calibration mode, meanwhile, the buzzer will sound three times for prompt.
2. Steering Wheel Calibration: Turn the steering wheel to the max and min travel point clockwise/counterclockwise respectively, and the buzzer will sound two times for prompt.
3. Throttle Trigger Calibration: Push/pull the throttle trigger to forward/backward as far as it will go, and the buzzer will sound once for prompt.
4. CH5 Knob Calibration: Turn the CH5 knob to its max and min travel point clockwise/counter-clockwise respectively, and the buzzer will give a long beep.
5. Press the BIND button to save and exit in case of the calibration is successful, and the buzzer will give a long beep.

**\* If the calibration fails, pressing the BIND button is invalid. Repeat the steps above.**

当油门、手轮和 CH5 旋钮发生机械性偏离，如回中或最大 / 最小行程出现偏差时，使用此功能修正。步骤如下：

1. 同步将手轮顺时针打到最大、扳机往前推到底并开机，进入校准模式，发射机蜂鸣器响 3 声提示；
2. 手轮校准：将手轮分别按顺时针和逆时针方向转至最大和最小行程，发射机蜂鸣器响 2 声提示；
3. 扳机校准：将扳机分别向前和向后推至最大和最小行程，发射机蜂鸣器响 1 声提示；
4. CH5 旋钮校准：将 CH5 旋钮分别按顺时针和逆时针方向转到最大和最小行程，发射机蜂鸣器长响 1 声提示；
5. 按 BIND 键退出并保存校准数据，发射机蜂鸣器长响 1 声提示。

**\* 若校准失败，按 BIND 键无反应，请重复以上校准步骤。**

## Power Off 关机

Follow the steps below to turn off the system:

1. Turn off the receiver first.
2. Toggle the transmitter's power switch to the [OFF] position.

请按以下步骤关闭发射机:

- 1、先断开接收机电源;
- 2、将电源开关拨到 [OFF] 位置, 关闭发射机。



**Danger**  
危险

Make sure to disconnect the receiver power before turning off the transmitter. Failure to do so may lead to damage or serious injury.

关闭时, 请务必先关闭接收机电源, 再关闭发射机, 否则可能导致模型损坏、人员受伤。

## System Functions

## 系统功能

This section focuses on the functions and how to use them.

此章节主要介绍系统各项功能操作。

### Channel Description 通道说明

The transmitter outputs a total of 6 channels, which are assigned as below, as well as the functions.

该发射机共输出11个通道, 控件分配及相关功能如下:

Channel 通道	Assigned Control 已分配的控件	Function 功能
CH1	Steering Wheel 方向手轮	Steering, to make the model car to turn right or left. Turn the steering wheel in clockwise or counterclockwise to control the left/right steering. 方向, 控制车子左右转向。沿顺时针或逆时针方向旋转手轮, 可控制车子左右转向。
CH2	Throttle Trigger 油门扳机	Throttle, to control the model car to move forward or backward. Push or pull the throttle trigger to control the model car forward or backward. 油门, 控制车子前后行驶。推或扣油门扳机控制车子前进或后退。
CH3	CH3 Button CH3 按键	User can customize the channel function. For example, function as a fast / slow position servo channel. 可自定义通道功能, 如可作为快慢档舵机通道。
CH4	CH4 Button CH4 快慢档	TWO-SPEED TRANSMISSION 两档变速
CH5	CH5 Knob CH5 灯控	For the 2-in-1 receiver, it controls car lights, and for the standard receiver, it can be customized the channel function. 控制车灯 (二合一接收机), 也可自定义通道功能 (标准接收机)。
CH6	CH6 CH6	User can customize the channel function. 自定义三档开关
CH7	CH7 CH7	User can customize the channel function. 自定义开关
CH8	CH8 CH8	User can customize the channel function. 自定义开关
CH9	CH9 Knob CH9 旋钮	User can customize the channel function. For example, function as a fast / slow position servo channel. 可自定义通道功能, 如可作为快慢档舵机通道。
CH10	CH10 Self-locking Switch CH10 自锁开关	
CH11	CH11& Drag Brake Knob CH11& Drag Brake 旋钮	For the 2-in-1 receiver, it is used to set the ESC drag brake, and for the standard receiver, it can be customized the channel function. 设置电调刹车力度 (二合一接收机), 也可自定义通道功能 (标准接收机)。

## Channel Reverse 通道反向

This function reverses the motion direction of steering channel, throttle channel, CH3, CH4, CH7 and CH8 servos. The ST.REV and TH.REV switches are reverse setting switches of steering channel and throttle channel respectively. Switches 3, 4, 5 and 6 of the 6-bit DIP switch are the reverse setting switches of CH3, CH4, CH7, and CH8, respectively. A switch on the upper side indicates that the servo output is normal; a switch on the lower side indicates that the servo output is reverse.

**Setup:** Toggle the corresponding setting switch to the upper side, the buzzer will have one beep. Toggle the switch to the lower side, the buzzer will have two beeps.

该功能可将方向通道、油门通道、通道 3、通道 4、通道 7 和通道 8 舵机的动作方向反转。ST.REV 开关和 TH.REV 开关分别为方向通道、油门通道反向设置开关。六位拨码开关第 3、4、5 和 6 位开关分别为通道 3、通道 4、通道 7 和通道 8 反向设置开关。开关在上侧，表示舵机输出为正向；开关在下侧，表示舵机输出为反向。

**功能设置：** 将对应的设置开关拨至上侧，蜂鸣器响一声提示；将开关拨至下侧，蜂鸣器响两声提示。

## Trims 微调

This function can set the trims of steering channel, throttle channel, channel 4 and channel 6.

### CH6 Trim Adjustment

To adjust the trim of channel 6. The step is 5us, and setting range is from -120us to +120us.

#### Setup:

1. In the power-on state, rotate the steering wheel clockwise to its maximum point, and at the same time press BIND twice (within 1S) to enter the channel 6 trim setting state;
2. Press the CH7 button to decrease the trim value, when pressing CH7 once, the buzzer will sound once for prompt, and when it reaches the minimum value of -120us, the buzzer will be turned off;
3. Press the CH8 button to increase the trim value, when pressing CH8 once, the buzzer will sound once for prompt, and when it reaches the maximum value of 120us, the buzzer will be turned off;
4. Long press BIND for 1 second or restart the transmitter to exit the trim setting state. At this time, the buzzer will give a long beep.

### Trim Adjustment for Steering Channel, Throttle Channel and CH4

To adjust the trims of steering channel, throttle channel and channel 4.

The ST.TRIM, TH.TRIM and TRIM knobs correspond to the trim adjustments of the steering channel, throttle channel and CH4, respectively. When the knob is centered by default, the trim value is zero. When adjusting counterclockwise, the trim value increases to a maximum of 120us. When adjusting clockwise, the trim value decreases to a minimum of -120us. Note that when the channel is set in reverse, the trim is reversed at the same time, that is, the trim value decreases in the counterclockwise adjustment, and the trim value increases in clockwise adjustment.

#### Setup:

Turn the trim knobs corresponding to the channel clockwise or counterclockwise for trim adjustment. The buzzer will have one beep when the position is reached to the center.

**Note:** After the throttle trim is changed, the receiver needs to be re-powered on to recognize the new throttle neutral. Otherwise, an exception may occur during vehicle reversing.

该功能可设置方向通道、油门通道、通道 4 和通道 6 的微调。

### 通道 6 微调调节

调节通道 6 微调。设置步进 5us，设置范围 -120us~+120us。

#### 功能设置：

- 1、开机状态下，顺时针旋转方向手轮至最大，同时双击 BIND 键(1S 内)即进入通道 6 微调设置状态；
- 2、按 CH7 按键减小微调值，按一下则蜂鸣器响一声提示，至最小值 -120us 时，蜂鸣器关闭；
- 3、按 CH8 按键增大微调值，按一下则蜂鸣器响一声提示，至最大值 120us 时，蜂鸣器关闭；
- 4、长按 BIND 键 1S 或重启发射机即可退出微调设置状态，此时，蜂鸣器长响一声提示。

### 方向通道、油门通道和通道 4 微调调节

调节方向通道、油门通道和通道 4 微调。

ST.TRIM、TH.TRIM 和 TRIM 旋钮分别对应方向通道、油门通道和通道 4 微调调节。默认旋钮居中时，微调值为 0。逆时针调节

时，则增大微调值，最大为 120us；顺时针调节时，则减少微调值，最小为 -120us。注意当通道设置反向后，微调同步反向即逆时针调节时减少微调值，顺时针调节时增大微调值。

#### 功能设置:

顺时针或逆时针旋转通道对应的微调旋钮调节。过中位时，蜂鸣器响一声提示。

**注:** CH2 油门微调调整后，接收机须重新通电以识别新的油门中位，否则可能会出现倒车异常的现象。

## D/R 比率设置

This function is used to adjust the rate of steering channel and throttle channel, so that the servo actions tend to be sensitive.

ST.D/R is used to adjust the steering channel rate. TH.D/R is used to adjust the throttle channel rate. Turning the knob anticlockwise will increase the value. Turning the knob clockwise will decrease the value. Smaller values indicate finer adjustment. The range is from 0 to 100%.

#### Setup:

Turn the D/R knobs corresponding to the channel clockwise or counterclockwise for D/R adjustment. The buzzer will have one beep when the position is reached to the center.

该功能用于调节方向通道和油门通道的比率，使舵机动作趋于灵敏。

ST.D/R和TH.D/R旋钮分别对应方向通道和油门通道比率调节。逆时针调节数值增大，反之减小。数值越小调节越细腻，调节范围为0~100%。

**功能设置:** 顺时针或逆时针旋转通道对应的比率调节旋钮调节。过中位时，蜂鸣响一声提示。

## End Point Adjustment 能量设置

This function is used to adjust the end points of all channels, i.e. left and right angle of steering channel, forward and brake of throttle channel, and servo travel amount of CH3-CH11.

By default, it is used to set the steering channel end points. The end points setting of the others can be triggered by operating the control corresponding to this channel.

### Steering Channel End Point Adjustment

Adjust the end points of steering channel (the control of steering channel is steering wheel).

#### Setup:

1. In the power-on state, press BIND twice, then the transmitter enters the end point setting mode. At this time, G.LED will work in two-flash-one-off mode repeatedly, and the buzzer will prompt with beeping twice cyclically.
2. Rotate the steering wheel to the appropriate travel point and hold it. Press BIND. The buzzer will prompt with beeping once cyclically.
3. Take the center of the steering wheel as the reference, reverse the rotation of the steering wheel to the appropriate travel point and hold it. Press BIND. The buzzer will be turned off at this time.
4. Press BIND for one second to save the setting and exit the end point setting mode. The buzzer will give a long beep, and the G.LED will be solid on. The end points setting of the steering channel is finished.

### CH6 End Point Adjustment

Adjust the end points of CH6.

#### Setup:

1. In the power-on state, press BIND twice, then the transmitter enters the end point setting mode. At this time, G.LED will work in two-flash-one-off mode repeatedly, and the buzzer will prompt with beeping twice cyclically.
2. Toggle CH6 Toggle Switch to one position. The buzzer will prompt with beeping three times cyclically.
3. Rotate the steering wheel to the appropriate travel point and hold it. Press BIND. The buzzer will prompt with beeping twice cyclically. The setting of this position is completed.
4. Toggle CH6 Toggle Switch to another position. Rotate the steering wheel to the appropriate travel point and hold it. Press BIND. The buzzer will prompt with beeping once cyclically. The setting of this position is finished.
5. Toggle CH6 Toggle Switch to the last position. Rotate the steering wheel to the appropriate travel point and hold it. Press BIND. The buzzer will be off at this time. The setting of this position is finished.
6. Press BIND for one second to save the setting and exit the end point setting mode. The buzzer will give a long beep, and the G.LED will be solid on. The end points setting of CH6 is finished.

**Note:** The end point values of at least two positions should be set.

**Other Channels End Point Adjustment**

Adjust the end points of the other channels.

**Setup:**

1. Refer to previous content, to put the transmitter into the end point setting mode.
2. Operate the control corresponding to the channel which you want to set.
3. Rotate the steering wheel to the appropriate travel point and hold it. Press BIND. The buzzer will prompt with beeping once cyclically.
4. Rotate the steering wheel to the appropriate travel point and hold it. Press BIND. The buzzer will be off at this time.
5. Press BIND for one second to save the setting and exit the end point setting mode. The buzzer will give a long beep, and the G.LED will be solid on. The end points setting of this channel is finished.

**Notes:**

1. If there is no response from the transmitter when a control is operated during the setup process, it means that the setup fails. In this case, you need to set it again.
2. Except the steering channel and throttle channel, you can operate the corresponding control to trigger the end points settings of other channels after completing the settings of one channel. For example, in the end points setting of CH3, you can press the CH4 button after the buzzer is turned off. At this time, the buzzer prompts with beeping twice cyclically. You can continue the end points setting of CH4. If you want to set the end points of the steering channel or throttle channel after setting other channels, the transmitter needs to re-enter the end point setting mode.
3. Throttle channel will maintain normal output during the end point setting of other channels.

该功能用于所有通道的行程大小，即方向通道左、右角度调整，油门通道前进、刹车以及通道 3 到通道 11 的行程量的调整。默认设置方向通道舵量。可通过操作其他通道所对应的控件触发此通道的舵量设置。

**方向通道舵量调节**

调节方向通道(控件为方向手轮)舵量。

**功能设置:**

- 1、开机状态下，双击对码按键(BIND)使发射机进入舵量设置模式，此时 G.LED 指示灯为二闪一灭状态，蜂鸣器响 2 声循环提示；
- 2、旋转手轮至合适的行程处并保持，按下对码按键(BIND)，蜂鸣器变为响 1 声循环提示；
- 3、以手轮中位点为基准，反向旋转手轮至合适的行程处并保持，按下对码按键(BIND)，此时蜂鸣器关闭；
- 4、长按对码按键 (BIND)一秒保存设置并退出舵量设置模式，此时蜂鸣器长响一声提示，G.LED 指示灯变为常亮，方向通道舵量设置完成。

**通道 6 舵量调节**

调节通道 6 舵量。

**功能设置:**

- 1、开机状态下，双击 BIND 键，使发射机进入舵量设置模式，此时 G.LED 指示灯为二闪一灭状态，蜂鸣器响 2 声循环提示；
- 2、将 CH6 拨档开关拨至一处档位，蜂鸣器变为响 3 声循环提示；
- 3、旋转方向手轮至合适的行程处并保持，按下对码按键 (BIND)，蜂鸣器变为响 2 声循环提示，此档位位置舵量设置完成；
- 4、将 CH6 拨档开关拨至另一档位，旋转方向手轮至合适的行程处并保持，按下对码按键 (BIND)，蜂鸣器变为响 1 声循环提示，此档位位置舵量设置完成；
- 5、将 CH6 拨档开关拨至最后一个档位，旋转方向手轮至合适的行程处并保持，按下对码按键 (BIND)，此时蜂鸣器关闭，此档位位置舵量设置完成；
- 6、长按对码按键 (BIND) 一秒保存设置并退出舵量设置模式，此时蜂鸣器长响一声提示，G.LED 指示灯变为常亮。CH6 通道舵量设置完成。

**注：**舵量设置过程中至少要设置两个档位舵量数值。

**其他通道舵量调节**

调节其他通道行程量。

**功能设置:**

- 1、参照前面内容，使发射机进入舵量设置模式；
- 2、操作要设置的通道所对应的控件；
- 3、旋转手轮至合适的行程处并保持，按下对码按键 (BIND)，蜂鸣器变为响 1 声循环提示；
- 4、再一次旋转手轮至合适的行程处并保持，然后按下对码按键 (BIND)，此时蜂鸣器关闭；

5、长按对码按键 (BIND) 一秒保存设置并退出舵量设置模式, 此时蜂鸣器长响一声提示, G.LED 指示灯变为常亮。此通道舵量设置完成。

**注:**

- 1、若设置过程中按操作控件时发射机无响应则表示设置失败, 请按功能设置重新设置;
- 2、除方向通道和油门通道外, 其他通道可在设置完上一通道舵量后, 操作相应的控件触发其它通道的舵量设置。如当设置CH3通道舵量, 在蜂鸣器关闭后, 可按下CH4 按键, 此时蜂鸣器变为响 2 声循环提示, 即可继续设置 CH4 通道舵量。若设置完其他通道后再设置方向通道或油门通道舵量, 则须使发射机重新进入舵量设置模式后方可设置;
- 3、在非油门通道舵量设置过程中, 油门通道将保持正常输出。

## ESC Parameters Setting 电调参数设置

The function is adapted to a 2-in-1 receiver. The ESC parameters can be set by the 6-bit DIP Switch of the transmitter, that is, the DIP switch is located at different positions and the corresponding parameter values are different. There are two parameters can be set for the ESC, which are "Running Mode", "Battery Type".

**Running Mode**

Forward/Reverse(F/R): This mode adopts "one click" reverse mode, that is, when the throttle trigger is pushed from neutral range to the reverse area, the motor immediately generates reverse action, which is generally applied to rock crawler.

Defaults to forward/reverse mode and does not support switching on this model car.

**Battery Type**

There are LiPo and NiMH cells. It can be set according to the actual use.

The switch marked 2 of 6-bit DIP switch is used to set the battery type. The switch on the upper side indicates that the battery type is NiMH cells; and the switch on the lower side indicates that the battery type is LiPo.

**Setup:**

Toggle the switch 2 to the upper side, the buzzer will have one beep. Toggle the switch to the lower side, the buzzer will have two beeps.

此功能适配二合一接收机使用。可通过发射机的拨码开关设置电调参数, 即拨码开关位于不同位置对应参数值不同。有2个参数可以设置, 分别是“运行模式”、“电池类型”。

**运行模式**

正转 /反转:此模式采用“单击式”倒车方式, 即油门扳机从中点区域推至反向区域时, 电机立即产生倒车动作, 该模式一般用于攀爬车等特种车辆。

该车辆默认为正转/反转模式, 暂不支持切换

**电池类型**

有锂电和镍氢两种选择, 根据实际使用情况设置即可。

六位拨码开关第 2 位开关用于设置电调电池类型, 开关在上侧, 表示电池类型为氢;开关在下侧, 表示电池类型为锂电。

**功能设置:**

将拨码开关2 拨至下侧, 蜂鸣器响两声提示;将拨码开关1拨至上侧, 蜂鸣器响一声提示。

## Failsafe 失控保护

The failsafe function is used to protect the model and personnel when the receiver is out-of-control.

By default, it is not set, and the PWM interfaces will maintain the last output in case of out-of-control. The setting steps are as following.

**Setup:**

In the normal power-on state, set the control corresponding to the channel to be configured with failsafe to the preset position, meanwhile, press and hold the BIND button for 3 seconds to set the output value as the failsafe value. And the buzzer will give a long beep indicating that the setting is successful.

**Notes:**

1. When a 2-in-1 receiver has connected, the failsafe for CH2 is enabled by default, the ESC will enter the brake state when the receiver is out-of-control.

## 2. Restore to the default setting in case of re-binding.

此功能用于当接收机无法正常收到发射机的信号不受控制时，保护模型和操作人员的安全。

本发射机默认未设置时接收机通道保持最后输出。

### 功能设置:

开机正常状态下，操作需要设置失控保护的通道对应的控件至预设的位置，再长按对码按键(BIND)三秒，将当下输出的通道值设置为失控保护值。设置成功时，蜂鸣器长响一声提示。

### 注:

- 1、若对码的是二合一电调接收机，失控后接收机自动进入刹车模式；
- 2、重新对码时恢复默认设置。

## Idle Alarm 闲置报警

The transmitter will go into idle alarm state when there is no operation over 10 minutes.

When the transmitter is in idle alarm state, the G.LED will be in gradual light state, and the buzzer will prompt with beeping twice cyclically. Operate steering wheel or throttle trigger to cancel the idle alarm.

当发射机未操作时间大于 10 分钟时，即进入闲置报警状态。

在此状态下，发射机 G.LED 指示灯为呼吸灯状态且蜂鸣器响 3 声循环提示。闲置报警状态下，操作发射机的手轮或扳机可退出闲置报警状态。

## Sleep Mode 休眠模式

When the transmitter has been in idle alarm state over 2 minutes, it will enter the sleep mode.

In this mode, the G.LED will be in gradual light status, other indicators will be off, and the buzzer and RF will turn off. To exit the sleep mode, power off the transmitter and restart it.

当发射机处于闲置报警状态时间大于2分钟时，即进入休眠模式。

在此模式下，发射机 G.LED 指示灯为呼吸灯状态提示，其他指示灯灭，蜂鸣器关闭，RF 关闭。

须重启发射机才可退出休眠模式。

## Transmitter Voltage Alarm 发射机电压报警

When the system detects a low voltage, it will give an alarm. Avoid accidents caused by long-term operation under low voltage.

When the voltage is detected below 4.2V/7.0V (AA battery/LiPo battery), there is an alarm due to low voltage. At this time, the G.LED will flash slowly, and the buzzer prompts with beeping once cyclically.

When the voltage is detected below 3.5V (ultra-low), the transmitting function is disabled. The G.LED will be in gradual light state.

当系统检测到低电压时，即发出报警。避免控制系统在低电压状态下长时间运行造成意外。

当检测到电压低于 4.2V/7.0V (AA 电池 /LiPo 电池)，即进入低电报警状态，此时 G.LED 指示灯慢闪状态，蜂鸣器响 1 声循环提示。

当检测到电压超低时（低于 3.5V 时），发射功能关闭，G.LED 指示灯为呼吸灯状态提示。

## Data Reset 数据复位

This function is used to restore the end point value set to the default value.

### Setup:

To restore to the default value, press the BIND and CH4 buttons of the transmitter at the same time, and power the transmitter on. At this time, the buzzer will give a long beep.

**Note:** This function is only applicable to resetting the end point value set to the default value.

## System Functions

## 系统功能

此功能用于将设置的舵量数值恢复为默认值。

### 功能设置:

同时按住对码按键 (BIND) 和 CH4 按键后, 并通电开机, 即恢复成默认值, 蜂鸣器长响一声提示。

**注:** 此功能仅适用于复位舵量至默认值。

## Product Specifications

## 产品规格

Product Model	FS-MG11-BS	产品型号	FS-MG11-BS
Compatible Receivers	FS-R11D-BS	适配接收机	FS-R11D-BS
Compatible Models	Model car	适配模型	遥控车
Number of Channels	11	通道个数	11
RF	2.4GHz ISM	无线频率	2.4GHz ISM
Maximum Power	<20dBm (e.i.r.p.) (EU)	发射功率	<20dBm (e.i.r.p.) (EU)
2.4GHz Protocol	2A-BS	无线标准	2A-BS
Distance	>150m(Ground Distance without Interference)	遥控距离	不低于 150m (空旷无干扰地面距离)
Resolution	4096	通道分辨率	4096
Input Power	AA*4 or 2S LiPo	输入电源	AA*4 或 2S 锂电池
Working Current	About 60mA/6V	工作电流	60mA 左右 /6V
Transmitter Voltage Alarm	AA Battery: <4.2V LiPo Battery: <7.0V	低电压报警	AA 电池: <4.2V; LiPo 电池: <7.0V
Antenna	Single Built-in Antenna	天线类型	内置单天线
Charging Interface	None (The Type-C USB port is only used for power supply.)	充电接口	无 (USB 接口仅做供电使用)
Online Update	None	在线更新	无
Temperature Range	-10℃ ~ +60℃	温度范围	-10℃ ~ +60℃
Humidity Range	20% ~ 95%	湿度范围	20% ~ 95%
Color	Black	外观颜色	Black
Dimensions	135.7*189.5*82.7mm	外形尺寸	135.7*189.5*82.7mm
Weight	225g	机身重量	225g
Certifications	CE, FCC ID: 2A2UNMG1100	认证	CE, FCC ID: 2A2UNMG1100

## Receiver Overview 接收机预览

FS-FMS-R11D-BS based on 2A-BS protocols is a receiver which provides 11-channel and bidirectional transmission, featuring an external antenna, PWM signal output and LED lights signal output. It can be adapted to a variety of RC cars.

FS-FMS-R11D-BS 是一款采用 2A-BS 通信协议，提供 11 通道的双向接收机，外置单天线，输出 PWM 信号和车灯信号，可适配多种模型车使用。

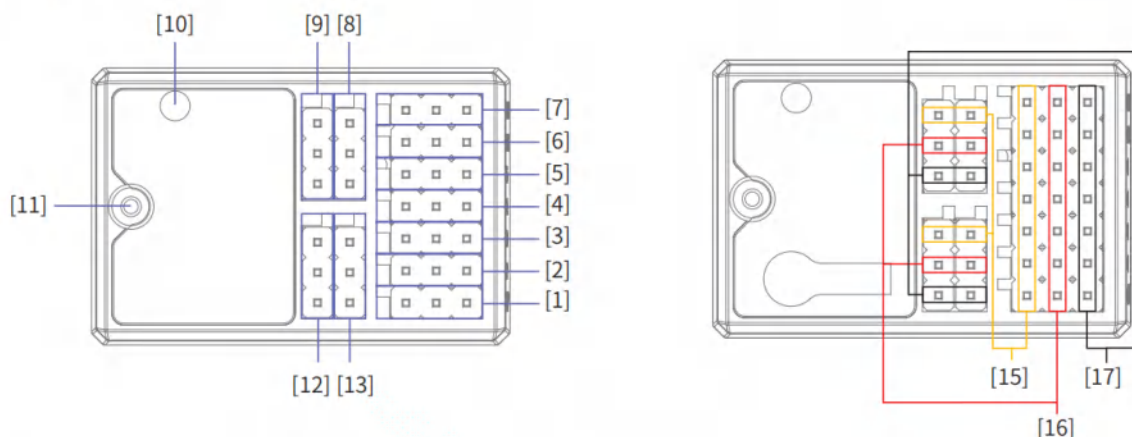

[1] CH1	[5] LED Light Connector	[9] CH11	[13] CH8
[2] CH2	[6] CH6	[10] LED	[14] S (Signal Pin of CH Connector)
[3] CH3	[7] CH7	[11] Antenna	[15] "+" (Anode of CH Connector)
[4] CH4	[8] CH10	[12] CH9	[16] "-" (Cathode of CH Connector)
[1] CH1 通道接口	[5] LED 车灯接口	[9] CH11 通道接口	[13] CH8 通道接口
[2] CH2 通道接口	[6] CH6 通道接口	[10] LED 指示灯	[14] S (通道接口信号端)
[3] CH3 通道接口	[7] CH7 通道接口	[11] 天线	[15] "+" (通道 / 车灯接口正极)
[4] CH4 通道接口	[8] CH10 通道接口	[12] CH9 通道接口	[16] "-" (通道 / 车灯接口负极)

**Note:** The LED Light Connector is used to connect the FS-DB01 car light drive board.

注：LED 车灯接口用于连接 FS-FMS-DB01 车灯驱动板。

## Binding 对码

This receiver supports the two-way binding (the transmitter will display the information returned from the receiver after the two-way binding is finished).

**The receiver will automatically enter binding status upon power-on. The operation steps are as follows:**

1. Put the transmitter into binding mode (The transmitter may enter binding mode in different ways, please follow the transmitter's manual).
2. Turn on the receiver, and it will wait 2 seconds for connection. If without connection, the receiver will enter the binding mode automatically. At this time, the receiver LED will be flashing fast.
3. The receiver LED will be solid on after the binding process is successful.
4. Check to make sure the transmitter and receiver functions are operating correctly, repeat steps 1 to 3 (binding process) if any problems arise.

**Note:** During the binding mode, put the transmitter into binding mode first, then put the receiver into binding mode, if the binding process is not finished within 10 seconds, then the receiver LED will enter a slow flashing status.

本接收机支持双向对码，双向对码完成后发射机将显示接收机回传的信息。

**本接收机上电即自动进入对码状态。如需对码接收机与发射机，操作步骤如下：**

- 1、将发射机进入对码状态（发射机进入对码状态的方式可能不同，请根据发射机的使用说明书进行操作）；

- 2、接收机,上电等待 2 秒没有连接将自动进入对码;
- 3、对码成功后,接收机 LED 指示灯常亮;
- 4、检查发射机、接收机是否正常工作。如需重新对码,请重复以上步骤。

**注:** 对码时请先将发射机进入对码状态,再将接收机进入对码状态,若10秒内对码没有完成,接收机指示灯进入慢闪状态。

## Fail-safe 失控保护

The failsafe function is used when radio signal connection is lost between the transmitter and receiver. The receiver performs channel output according to the set fail-safe value to protect the safety of the model and personnel.

- It is not set by default, After out-of-control, no matter whether the CH2 channel is set or not, there will be always no output and the other channels (CH1, CH3-CH4, CH6-CH11) will keep the last output, if the other channels have been set at the transmitter side, it will output according to the set value.
- The turn signal left and right lights will flash slowly and simultaneously.

失控保护功能用于当接收机无法正常收到发射机的信号不受控制时,保护模型和操作人员的安全。

- 默认未设置。失控后,无论是否设置 CH2 通道始终无输出,接收机其他通道(CH1、CH3-CH4、CH6-CH11)保持最后输出。若其他通道已在发射机端设置,则按照设置值输出。
- 左、右车灯同步慢闪提示。

## ! Attention 注意事项

- Make sure the product is installed and calibrated correctly, failure to do so may result in serious injury.
- Make sure the receiver's battery is disconnected before turning off the transmitter, failure to do so can result out of control. Unreasonable setting of the Failsafe may cause accidents.
- Make sure the receiver is mounted away from motors, electronic speed controllers or any device that emits excessive electrical noise.
- Keep the receiver's antenna at least 1cm away from conductive materials such as carbon or metal.
- Do not power on the receiver during the setup process to prevent loss of control.
- 使用前必须确保本产品与模型安装正确,否则可能导致模型发生严重损坏。
- 关闭时,请务必先关闭接收机电源,然后关闭发射机。如果关闭发射机电源时,接收机仍然在工作,将会导致遥控设备失控。失控保护设置不合理可能引起事故。
- 确保接收机安装在远离电机或电子噪声过多的区域。
- 接收机天线需远离导电材料,例如金属棒和碳物质。为了避免影响正常工作,请确保接收机天线和导电材料之间至少有1厘米以上的距离。
- 准备过程中,请勿连接接收机电源,避免造成不必要的损失。

## LED Lights Control 车灯控制方式

This receiver features six sets of LED lights: Turn signal left light, turn signal right light, daytime running light, headlight, brake light and reverse light. And these six sets of LED lights are connected to this receiver through the FS-FMS-DB01 car light driver board.

The status of all the LED lights is controlled by the corresponding controls of the FS-FMS-MG11-BS transmitter.

The turn signal left light and turn signal right light are controlled by steering wheel. The daytime running lights and headlights are controlled by CH5 knob. The brake and reverse lights are controlled by throttle trigger.

**Details are as follows:**

本接收机支持6组车灯:左转灯、右转灯、日行灯、前大灯、刹车灯和倒车灯(此6车灯通过 FS-FMS-DB01 车灯驱动板与本接收机建立连接)。

车灯状态由 FS-FMS-MG11-BS 发射机的相应控件控制。

左、右转向灯亮灭状态由手轮控制,日行灯和前大灯亮灭状态由 CH5 旋钮控制,刹车灯和倒车灯亮灭状态由扳机控制。

**具体有如下所述:**

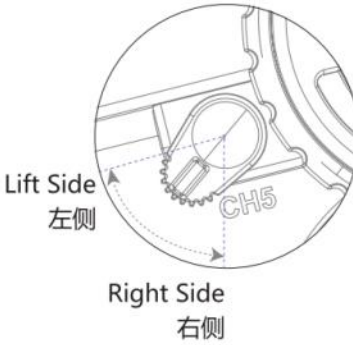
Car Lights 车灯	Car Light State 车灯状态	Control State 控制状态	Control 控件	Trigger Condition 触发条件	Notes 备注
Left Turn Signal Light 左转灯	Slow Flash 慢闪	Turn Left 左转	Steering Wheel 手轮	Turn the steering wheel counter clockwise. 逆时针打手轮	If you set the steering channel in reverse, the trigger condition for left and right turn signal lights will not be affected. 方向通道设置反向后对左、右转向灯无影响。
Right Turn Signal Light 右转灯	Slow Flash 慢闪	Turn Right 右转	Steering Wheel 手轮	Turn the steering wheel clockwise. 顺时针打手轮	
Daytime Running Light 日行灯	OFF 常灭	/	CH5 Knob CH5 旋钮	CH5 Knob is located at the left side. CH5 旋钮位于左侧	
	Solid ON 常亮			CH5 Knob is located in the middle. CH5 旋钮位于中间	
	Solid ON 常亮			CH5 Knob is located at the right side CH5 旋钮位于右侧	
Headlight 前大灯	OFF 常灭	/	CH5 Knob CH5 旋钮	Same as the DRL above 触发条件同日行灯	
	OFF 常灭				
	Solid ON 常亮				
Brake Light 刹车灯	Solid ON 常亮	Brake 刹车	Trigger 扳机	Push the throttle trigger forward. 前推扳机	/
Reverse Lights 倒车灯	Solid ON 常亮	Back up 倒车	Trigger 扳机	Push the throttle trigger forward. 前推扳机	/

**Notes:**

1. After the receiver is turned on, all the LED lights will be on for one second and then go out;
2. The steering CH1 channel and throttle CH2 channel are capable of automatic neutral identifying, after the trim is adjusted, the receiver should be powered to recognize the neutral positions of these two channels automatically.

**注:**

- 1、接收机开机后，所有车灯常亮一秒后灭；
- 2、方向通道 CH1 和油门通道 CH2 具有自动识别中位的功能，当调过微调后，需重新给接收机上电以完成中位自动识别。

## Receiver Specifications 接收机规格

Product Model	FS-FMS-R11D-BS	产品型号	FS-FMS-R11D-BS
Adaptive Transmitters	FS-FMS-MG11-BS	适配发射机	FS-FMS-MG11-BS
Number of Channels	Model car	适配模型	遥控车
Compatible Models	11	通道个数	11
Number of Car Light Interfaces	6 (The LED Light connector connects to the FS-FMS-DB01)	车灯组数	6 (LED 车灯接口连接 FS-FMS-DB01 车灯驱动板)
Compatible Models	2.4GHz ISM	无线频率	2.4GHz ISM
Maximum Power	<20dBm (e.i.r.p.) (EU)	发射功率	<20dBm (e.i.r.p.) (EU)
Antenna	Single External Antenna (Coaxial Antenna)	天线类型	外置单天线 (同轴天线)
Distance	>150m(Ground Distance without Interference)	遥控距离	不低于 150m (空旷无干扰地面距离)
2.4GHz Protocol	2A-BS	无线协议	2A-BS
Resolution	4096	通道分辨率	4096
Data Output	PWM	数据输出	PWM
Operating Voltage	3.5 ~ 8.4V/DC	工作电压	3.5 ~ 8.4V/DC
Online Update	None	在线更新	无
Temperature Range	-10℃ ~ +60℃	温度范围	-10℃ ~ +60℃
Humidity Range	20% ~ 95%	湿度范围	20% ~ 95%
WaterProof	PPX4	防水等级	PPX4
Dimensions	35.0mm*23.3mm*13.3mm	外形尺寸	35.0mm*23.3mm*13.3mm
Weight	8g	机身重量	8g
Certifications	CE, FCC ID: 2A2UNR11P01	认证	CE, FCC ID: 2A2UNR11P01

## Car Light Drive Board

## 车灯驱动板

## Car Light Drive Board Overview 车灯驱动板概览

FS-DB01 is a car light driver board for the FS-R11D-BS receiver. This light board has 6 sets of car light interfaces, and each set of car light can be independently controlled. The waterproof rate is PPX4.

FS-DB01是一款适配 FS-R11D-BS 接收机使用的车灯驱动板。本灯板具有6组车灯接口，且各组车灯可独立控制，防水性能达PPX4级。

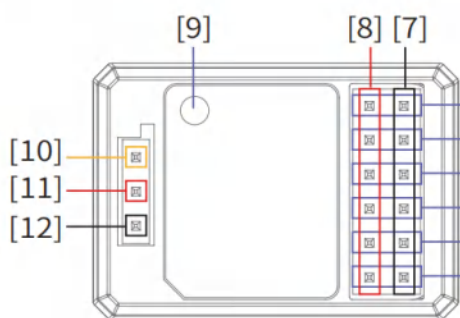

- [1] Left Turn Signal Light Interface
- [2] Right Turn Signal Light Interface
- [3] Daytime Running Light Interface
- [4] Headlight Interface
- [5] Brake Light Interface
- [6] Reversing Light Interface
- [7] "-" (Car Light Interface Cathode)
- [8] "+" (Car Light Interface Anode)
- [9] LED
- [10] S (Signal Input Interface Signal Pin)
- [11] "+" (Signal Input Interface Anode)
- [12] "-" (Signal Input Interface Cathode)

- [1] 左转灯接口
- [2] 右转灯接口
- [3] 日行灯接口
- [4] 前大灯接口
- [5] 刹车灯接口
- [6] 倒车灯接口
- [7] "-" (车灯接口负极)
- [8] "+" (车灯接口正极)
- [9] LED 指示灯
- [10] S (信号输入接口信号端)
- [11] "+" (信号输入接口正极)
- [12] "-" (信号输入接口负极)

### Notes:

1. All car light interfaces are 2.54mm\*2 Pin standard pins, and the signal input interface is 2.54mm\*3 Pin standard pins;
2. The signal input interface is used to connect FS-R11D-BS receiver.

### 注:

- 1、所有车灯接口均采用标准 2.54mm\*2 Pin 排针，信号输入接口采用标准2.54mm\*3 Pin 排针；
- 2、信号输入接口用于连接 FS-R11D-BS 接收机。

## Functions 功能相关

Connection between car light drive board and receiver:

Connect the car light drive board to the LED interface of the FS-R11D-ESC-BS receiver through the signal input interface.

### LED Status

- When the LED is solid on, the car light driver board is in normal working state.
- When the LED flashes slowly, the car light driver board does not receive valid signals.

车灯驱动板与接收机连接:

将车灯驱动板通过信号输入接口与FS-R11D-ESC-BS接收机的LED灯接口相连接。

### LED状态说明

- LED指示灯常亮，车灯驱动板为正常工作状态
- LED指示灯慢闪，车灯驱动板未收到有效信号

## Car Light Drive Board Specifications 车灯驱动板信息

Product Model	FS-DB01	产品型号	FS-DB01
Adaptive Receivers	FS-R11D-BS	适配接收机	FS-R11D-BS
Adaptive Model	RC Car	适配模型	RC Car
Number of Car Light Interfaces	6	车灯组数	6
Input Power	3.5~8.4V/DC	输入电源	3.5~8.4V/DC
Working Current	20mA/5V	工作电流	20mA/5V
Temperature Range	-10°C ~ +60°C	温度范围	-10°C ~ +60°C
Humidity Range	20% ~ 95%	湿度范围	20% ~ 95%
Water Proof	PPX4	防水等级	PPX4
Dimensions	27.0mm*19.0mm*13.5mm	外形尺寸	27.0mm*19.0mm*13.5mm
Weight	4.2g	机身重量	4.2g
Certifications	CE, FCC	认证	CE, FCC

- Make sure the product is installed and calibrated correctly, failure to do so may result in serious injury.
  - Please carefully check each power device and car frame instructions to ensure the power matching is reasonable before use. Avoid damaging power system due to incorrect matching.
  - Do not let the external temperature of the system exceed 90°C /194°F, because high temperature will damage the power system.
  - Make sure the receiver's battery is disconnected before turning off the transmitter, failure to do so can result out of control. Unreasonable setting of the Failsafe may cause accidents.
  - After use, remember to disconnect the battery and the ESC. If the battery isn't disconnected, the ESC will consume electric energy all the time even if it is off. It will discharge completely if connect the battery for a long time, thus resulting in the failure of the battery or the ESC. We are not responsible for any damage caused by this!
  - Make sure the receiver is mounted away from motors or any device that emits excessive electrical noise.
  - Keep the receiver's antenna at least 1cm away from conductive materials such as carbon or metal.
  - Do not power on the receiver during the setup process to prevent loss of control.
  - If the throttle trim is changed on the transmitter side, the receiver needs to be re-powered to recognize the new throttle neutral. Otherwise, an exception may occur during vehicle reversing.
- 使用前必须确保本产品与模型安装正确，否则可能导致模型发生严重损坏。
  - 请查看各动力设备以及车架说明书，确保动力搭配合理，避免因错误的搭配导致动力系统损坏。
  - 勿使系统的外部温度超过 90°C/194 °F，高温将会毁坏动力系统。
  - 关闭时，请务必先关闭接收机电源，然后关闭发射机。如果关闭发射机电源时接收机仍然在工作，将导致遥控设备失控。失控保护设置不合理可能引起事故。
  - 使用完毕后，若长时间不玩车，切记断开电池与电调的连接。如电池未断开，即使电调开关处于关闭状态，电调也会一直消耗电能（只是非常小）长时间连接电池最终会被过放，进而导致电池或电调出现故障。我们不对因此而造成的任何损害负责！
  - 确保接收机安装在远离电机或电子噪声过多的区域。
  - 接收机天线需远离导电材料，例如金属棒和碳物质。为了避免影响正常工作，请确保接收机天线和导电材料之间至少有1厘米以上的距离。
  - 准备过程中，请勿连接接收机电源，避免造成不必要的损失。
  - 若在发射机端调整油门通道微调后接收机须重新通电以识别新的油门通道中位，否则可能会出现倒车异常的现象。

## Troubleshooting

## 故障快速处理

Troubles 故障现象	Possible Causes 可能原因	Solutions 解决方法
The motor cannot start and the LED is not on after power-on.  上电后，指示灯不亮，电机无法启动	1. The ESC has no working voltage. 2. The switch of ESC or ESC itself is damaged.  1. 电调没有得到工作电压；2. 接收机开关或电调损坏。	1. Check whether there is any connection problem between the battery and ESC and whether there is faulty welding of the relevant plug.2. Return to factory for inspection and treatment.  1. 检查电池与电调有无连接问题以及相关插头是否有虚焊情况；2. 返厂检测处理。
The motor cannot start after power-on.  上电后，电机无法启动	The throttle channel neutral of the transmitter is shift or changed.  发射机油门通道的中点偏移或改变。	1. Ensure that the transmitter trigger is in its natural state when re-powering the transmitter.2. Adjust the throttle channel of the transmitter by trim function to match the existing neutral position of ESC.  1. 重新上电时，确保发射机扳机处于自然状态； 2. 调节发射机油门通道微调使之匹配电调现有中立点。

Troubles 故障现象	Possible Causes 可能原因	Solutions 解决方法
When forward the car by the transmitter, it reverse. 发射机做前进操作，车子反而倒退	1. It may cause by the connection sequence between output line of ESC and motor line.2.The throttle direction of transmitter is wrongly set. 1. 电调输出线和电机线的连接线序错误；2. 发射机油门方向设置错误。	1. Exchange the position of two lines of motor.2. Set throttle direction of transmitter to the opposite direction. 1. 将电机的两条线互换位置即可；2. 将发射机油门方向设置为相反方向。
When forward the car by the transmitter, it reverse. 电机转动过程中，突然停转	1. It may cause by the connection sequence between output line of ESC and motor line.2.The throttle direction of transmitter is wrongly set. 1. 油门信号丢失；2. 电调进入电池低压保护或过热保护。	1. Exchange the position of two lines of motor.2. Set throttle direction of transmitter to the opposite direction. 1. 检查发射机和接收机；2. 请检查电池电压以及电调温度。
When the motor starts, it accelerates rapidly, and the motor is stuck or stops. 电机启动时急加速，电机有卡住或停顿的现象	1. Battery discharge capacity is insufficient.2. The rotation speed of motor is too fast, the gear ratio is not reasonable. 1. 电池放电能力不够；2. 电机转速过高，齿轮比搭配不合适。	1. Replace battery with strong discharge capacity.2. Replace low speed motor, or increase the reduction ratio. 1. 更换放电能力强的电池；2. 更换低速电机，或将减速比提高。

## Attention 注意事项

- Do not let children use this product without the supervision of an adult.
- The ESC might get hot during use, be careful when handling it.
- When soldering input/output wires and connections, set the iron to 60W minimum.
- Always disconnect the battery after use, do not store with the battery connected.
- Do not use near flammable materials.
- If the ESC overheats, emits smokes or burns, immediately discontinue use, disconnect the battery and seek assistance.
- 不能让小孩在无成人监管的情况下使用此产品。
- 电调在使用过程中可能会变烫,拿的时候要小心。
- 若需对电调的输入输出线、插头做相关焊接时,请使用至少60W功率的焊接设备进行焊接。
- 不使用电调时需要断开电池。
- 使用电调时不能靠近易燃物品。
- 如果电调出现过热,冒烟或者着火,请立即停止使用,断开电池并寻求帮助。

## Features 特点

- Completely water-proof and dust-proof.
- 32-bit microprocessor can support more powerful processing capability and more accurate motor output.
- Excellent start-up, acceleration and linearity features.
- Multiple protection features: Low voltage cut-off protection, over-heat protection and throttle signal loss protection.
- 全防水设计, 适应各种气候环境。
- 电调使用了32位处理器,提供更加强大的运算能力及更精准的油门输出。
- 更加优秀的油门启动、加速度及油门线性。
- 多重保护功能:电池低压保护、过温保护、油门信号丢失保护。

## Specification 产品规格

Product Name	Cont./ Peak Current	Input	BEC Output	Size (mm)	Weight (g)	ESC Programming	ESC Firmware upgrading
产品名称	持续/峰值电流	电池节数	BEC输出	尺寸	重量	参数编程功能	是否支持软件升级
SL 50A	50A/300A	2-3S Lipo	6V/3A	49*38*20	73g	No	Yes

## Connection 电调连接-示意图

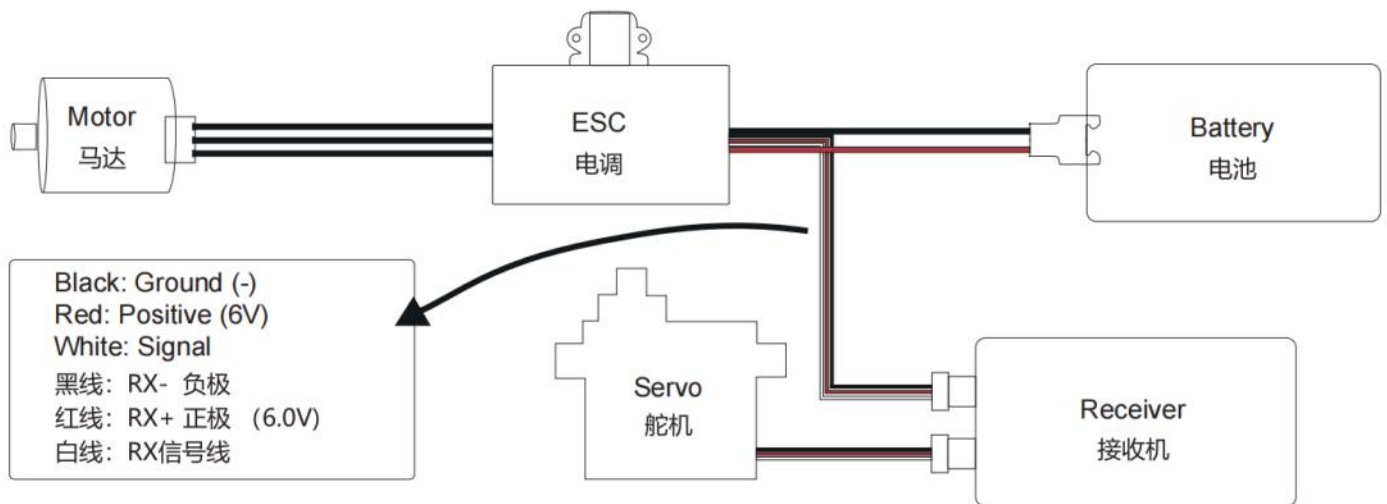

### Battery Wire Connection:

When connecting the battery, pay attention to polarity: incorrect connection will damage the ESC and Battery. As shown in the figure above, connect the positive (+) wire is connected to (+) battery par, and the negative (-) wire is connected to the (-) battery port.

### Motor Wire Connection:

The #A, #B, #C wires of the Esc can be connected with the motor wires freely (without any sequencel). If the motor runs in the oppoite direction, please eschang any two wites connections.

### Receiver Wire Connection:

The signal wire provides 6.0V to the receiver, servo, etc., so no additional batteries are needed, and external power to the receiver may damage the ESC.

Black wire: RX-

Red wire: RX+6.0V

White wire: RX-Signal

### 电池连接:

电调连接电池时,要特别注意正负极位置,错误的连接会损坏电调和电池。如上图所示,电调正极线连接电池的正极,负极线连接电池的负极。

### 电机连接:

电调与马达相连无严格的线序要求,电调的#A/#B/#C可以与电机的三线随意对接,若出现转向相反,任意交换两条马达线即可。

### 接收机连接:

信号线提供6.0V电压给到接收机、舵机等,所以不需要额外的电池,外接电源到接收机可能会损坏电调。

黑线: RX-负极

红线: RX+正极(6.0V)

白线: RX信号线

## Software Functions and Settings 电调软件功能及设置

### Power On/Off ESC

1. Press the power button then the ESC will be powered on;
  2. Press and holding the power button until the all LEDs died out, then the ESC will be powered off.
- Note: Please place the throttle trigger on the neutral position: within 10%, otherwise the ESC can not be powered off.

### Throttle Calibration

1. Turn on the transmitter ( moving the throttle trigger to the full throttle position);
2. Press and hold the switch until the blue LED turns on solid and the motor emits a long "beep" tone, indicating that the ESC has entered calibration mode;
3. Release the switch, the blue LED will flash three times, and the motor will emit a "beep" tone;
4. Move the throttle trigger to the full brake position, the blue LED will flash three times, and the motor will emit "beep, beep" tones;
5. Release the throttle trigger to the neutral position; the blue LED will flash three times, and the motor will emit "beep, beep beep" tones;
- 6 Turn off the ESC and then turn it on again, the throttle calibration is now completed.

### 开关机

- 1、短按电源键电调开机；
- 2、长按电源键至全部LED灯熄灭，电调将关机（油门离开中点10%距离后不能关机）。

### 校准油门行程：

- 1、打开近控器（油门放在最大位置）；
- 2、长按开关直到蓝灯常亮，马达长滴1声，电调进入油门校准模式；
- 3、松开开关。蓝灯闪三下，马达滴一声；
- 4、油门推到最小，蓝灯闪三下，马达滴两声；
- 5、油门回中，蓝灯闪三下，马达滴三声；
- 6、关机。重新开机，油门校准完成。

### LED Status LED灯指示

1. During operation 1. 操作中

Throttle Position 油门位置	Blue LED 蓝灯状态	Red LED 红灯状态
Neutral 中立位	Blinking 蓝灯闪	OFF 红灯灭
Full Throttle 最大油门位置	ON 蓝灯亮	ON 红灯亮
Full Brake 最大到车位置	OFF 蓝灯灭	ON 红灯亮

**Note:** When you pull the throttle from neutral position to full throttle position, the Blue LED will blink, and the blink frequency will go faster when the throttle goes higher.

**注：**蓝灯变频闪，油门正常，蓝灯的闪烁频率会随油门的大小变化，油门越大频率越高（肉眼可分辨）。

### 2. When some protection is activated

- The RED LED is always on solid once the power button is pressed.
- The RED LED blinks, single flash between every one second. Repeat like "※ ※ ※" indicates that the voltage is abnormal.
- The RED LED blinks, double flash between each one second. Repeat like "※※ ※※ ※※" indicates that the temperature is abnormal.
- The RED LED blinks, single and double flash alternately between each one second. Repeat like "※ ※※ ※ ※※ ※※ ※※" indicates that both of the voltage and temperature is abnormal at the same time.
- The RED LED will not have any responds every the voltage or temperature is abnormal if it's not detected the signal.
- The BLUE LED blinks, double flash between every two seconds. Repeat like "※※ ※※ ※※" indicates that the throttle is abnormal (No throttle, or the throttle is not on the neutral position).

### Trouble shooting 故障快速处理

Trouble shooting 故障现象	Possible causes 可能原因	Solutions 解决办法
The motor stuttered but couldn't start. 电机抖动，无法启动。	<ol style="list-style-type: none"> <li>1. Some soldering between the motor and the ESC was not good.</li> <li>2. The ESC was damaged (some MOSFETs were burnt).</li> </ol>	<ol style="list-style-type: none"> <li>1. Check all soldering points, please re-solder if necessary</li> <li>2. Contact the distributor for repair or other customer services.</li> </ol>
油门在中点时，车子缓慢前进或缓慢后退。	<ol style="list-style-type: none"> <li>1. The neutral position on the transmitter was not stable, so signals were not stable either.</li> <li>2. The ESC calibration was not proper.</li> </ol>	<ol style="list-style-type: none"> <li>1. Replace your transmitter</li> <li>2. Re-calibrate the throttle range or tune the neutral position on the transmitter.</li> </ol>
油门在中点时，车子缓慢前进或缓慢后退。	<ol style="list-style-type: none"> <li>1. 遥控器中位有漂移，导致信号不稳。</li> <li>2. 油门行程没校准好。</li> </ol>	<ol style="list-style-type: none"> <li>1、更换信号稳定的摇控器。</li> <li>2、重新校准油门行程。</li> </ol>

## Vehicle Setup

## 车辆设置

### Battery Precautions 电池注意事项

- Never charge a lithium polymer battery with a charger designed for NiCd, NiMH, or any other type of battery chemistry.
- Use ONLY charger designed for LiPo battery.
- Do not leave LiPo battery unattended during charging.
- Do not overcharge the battery.
- Always charge LiPo batteries on non-flammable, heat-resistant surfaces.
- Always use a LiPo-safe bag or container while charging.
- Do not allow LiPo cells to overheat at any time. Cells which reach greater than 140 Fahrenheit(60°C) will usually become damaged and will catch fire.
- Do not charge the LiPo pack while it is still in the model.
- Never charge or store battery packs in a vehicle.
- Do not discharge LiPo, doing so will damage the battery.
- Do not expose LiPo cell to water or moisture at any time.
- Do not store battery near open flame or heater.
- Do not assemble LiPo cells or pre-assembled packs together with other LiPo cells or packs.
- Always store LiPo battery in a secure location away from children.
- Always remove the LiPo battery if model is involved in any kind of crash.
- Carefully inspect the battery and connectors for even the smallest damage.
- CAUTION: Cells may become hot after usage.
- Allow the pack to cool to room temperature prior to recharging.
- Do not allow the electrolyte to get into eyes or on skin. Wash affected areas immediately if they come into contact with electrolyte.
- Do not alter or modify connectors or wires of a LiPo battery pack.
- Always inspect the condition of the battery before charging and operating.
- Do not short circuit the LiPo battery.
- Do not have contact with a leaky/damaged battery directly.
- Do not charge battery out of recommended temperature range(0°C-45°C).

- 不要使用NiCd、NiMH或任何其他类型的充电器给LiPO锂聚合物电池充电
- 请使用LiPO锂聚合物的专用充电器给LiPO锂聚合物电池充电
- 请勿在无人看管的情况下充电
- 电池请勿过充
- 请勿将电池放置在易燃、不耐热的表面上充电
- 总是使用安全袋或安全容器给电池充电
- 保证电池在任何时候都不过热。电池温度超过140华氏度（60°C）则易造成损坏，甚至引发火灾
- 请勿将电池长期置于模型产品内，更勿在模型产品内直接充。
- 请勿给电池放电，以免损坏电池
- 任何时候请勿将电池暴露在水或湿气之中
- 请勿在明火或加热器附近储放电池
- 请勿与其他未组装或预组装的电池混用
- 需将电池存放在远离儿童的安全位置
- 模型如出现任何碰撞，需立刻拆除电池。即使出现微小的损坏，也需仔细检查电池和连接器
- 注意：使用后电池可能会发热，需让电池冷却到室温后再进行充电
- 请勿让电解液接触眼睛或皮肤。如电解液不慎接触到身体的任何部位，请立即进行清洗
- 请勿替换或修改电池组的连接器或电线
- 在进行充电或其他任何操作之前需检查电池的状况
- 请勿造成电池短路
- 请勿直接接触已泄漏或已损坏的电池
- 请勿超出建议温度范围充电电池(0度-45度)

## Connecting the battery 连接电池

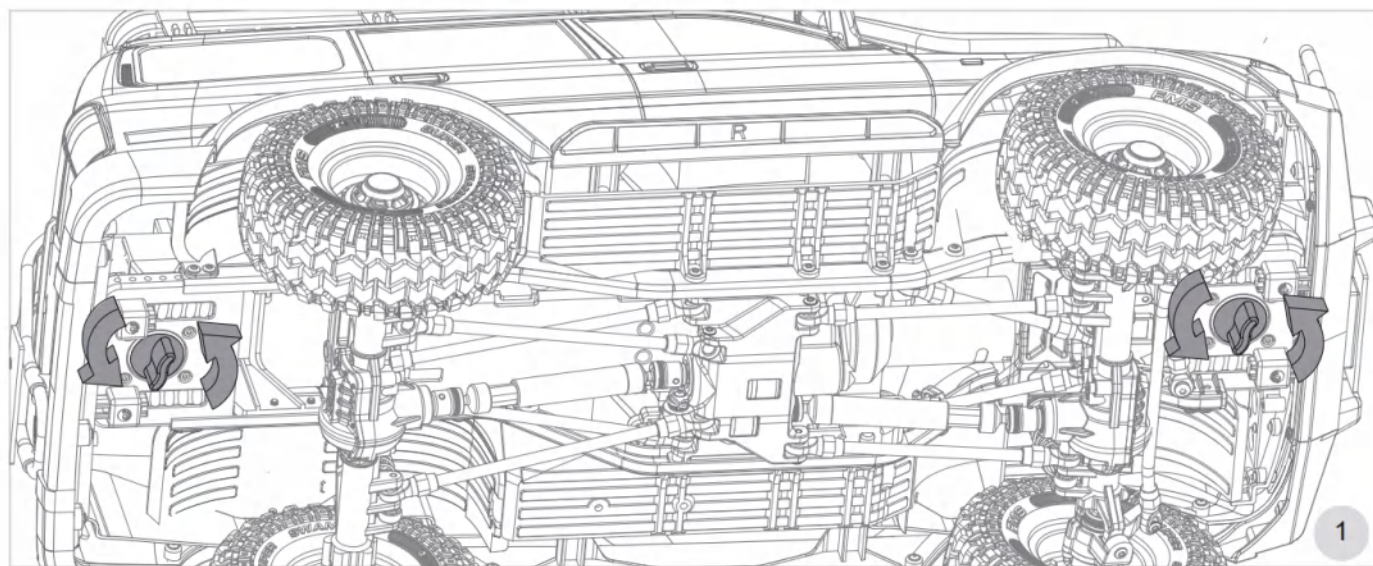

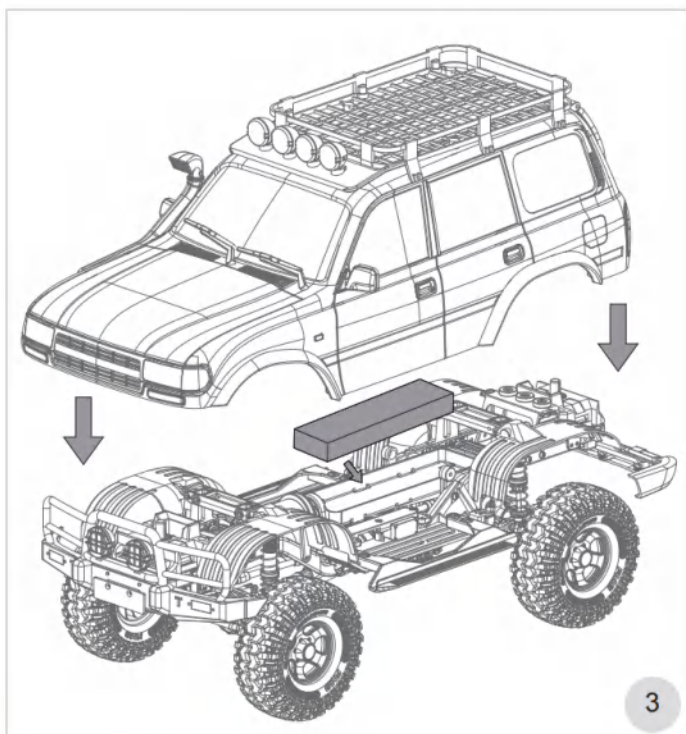
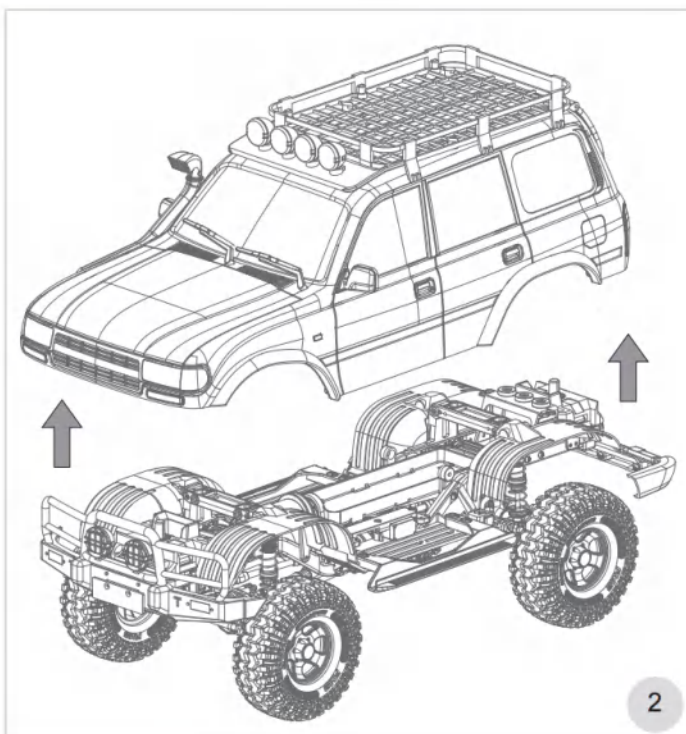

1. Gently push the front latches forward and the rear latches backward to separate the car shell from the chassis.
2. As shown in the diagram, place the battery inside the battery compartment and secure it in place using the included battery strap, Connect the battery to the RX/ESC 2-in-1 unit (batteries sold separately, recommended batteries are advised).
3. Align the front and rear pillars of the car shell with the corresponding snap joints on the chassis, then push them in to reattach the car shell onto When there is a "click" sound from the front and rear shells, it means the car body is installed in place.

Battery compartment size: 140\*47\*40mm

The battery plug: XT60 Male

- 1、将车头和车尾的扭扣旋转，以分离车壳与车底盘；
- 2、如图所示，将电池放入电池仓内，并使用附带电池扎带固定到位，连接电池至电调/接收二合一组件（电池需另购，建议使用推荐电池）；
- 3、将车壳的前后柱体对准并推入车底盘的前后扣位旋转纽扣，以当前后车壳有“咔嚓”声音，表示车壳安装到位。

电池仓尺寸：140\*47\*40mm

电池插头：XT60 公头



Note  
注意

1. Please remove the battery immediately after use (allow time for the battery to cool down) and do not store the battery inside the model product for an extended period.
  2. Do not open, disassemble, or attempt to repair the battery.
  3. The battery needs to be disconnected from vehicle before it can be charged
  4. Do not charge battery in vehicle.
- 1、请在使用后立即取出电池(需等待电池降温)，不可将电池长时间存放在模型产品内；
  - 2、不要打开、拆解或试图维修电池；
  - 3、在给电池充电之前，需要先断开电池与车辆的连接；
  - 4、请勿在车内给电池充电。

## Spare Parts List

## 配件列表

C3941	Transmission Gear Box Assembly Version V2	驱动牙箱总成 V2
C3206V2	Transmission Gear Box Housing V2	驱动牙箱壳胶件 V2
C3207	Motor Mount	电机码件
C3208	Slipper Sheet	限滑片
C3942	3541 Brushless Motor	3541 无刷电机
C4044	Brushless Gear Set For Transmission Gear Box	无刷变速箱齿轮
C3992V2	Transmission Gear Shift V2	变速箱轴 V2
C3213V2	Clutch Engage Switcher V2	离合器接合件 V2
C3943	Front Axle Assembly	前桥总成
C3696	Rear Axle Assembly	后桥总成
C3944	Front Oil Shock Absorbers Assembly 1pair	前避震器总成一对
C3945	Rear Oil Shock Absorbers Assembly 1pair	后避震器总成一对
C3219	Driftshaft Assembly	传动轴总成
C3220	Metal Frame Rail Set	金属大梁
C3221	Shock Absorbers Tower Set	避震架
C3698	Rear Girder Mount Set	后大梁连接件
C3223	Battery Box Set	电池箱零件
C3224V2	Transmission Box Mount V2	变速箱码件 V2
C3699V2	Chassis Side Plates V2	踏板 V2
C3230	Functional Servo Mount	功能舵机伺服码件
C3701V2	Universal Driveshaft Set Front V2	前轮传动轴组 V2
C3232	Front Axle Housing	前桥胶件
C3233	Rear Axle Housing	后桥胶件
C3234	Steering Servo Mount	转向舵机码件
C3235	Steering Linkage And Panhard Bar	转向拉杆及扯推杆
C3703	C Hub And Cover Set	C座及盖
C3706	Rear Axle Cover Parts	后桥轴盖胶件
C3702	Rear Wheel Driveshaft 1pair	后轮轴一对
C3704	Front / Rear Axle Gear Set	前/后桥轴齿套装
C3240	Drive Gear	驱动齿
C3242	17mm Hex Set With Set Screw Pins	17mm 六内接合件及机米螺丝
C3244	Pivot Balls	铝球头
C3245	Bushing Set	套筒介子
C3248	13G Metal Gear Servo Waterproof	13G金属齿舵机
C3249V2	13G Servo Saver Set With Horn Arm V2	13G舵机护器及舵机臂 V2
C3373	MG11 Transmitter	MG11 发射器
C3742	MG11 + FMS-R1D-BS Transmitter Receiver Set	MG11+FMS-R11D-BS 发射器/接收器
C3744V2	FMS-R11D-BS Receiver V2	FMS-R11D-BS 接收器 V2
C3266	Bearing Set	轴承
C3267	Wire Buckle	线扣
C3268	M4 Screw Nut	M4防滑螺母
C3194	Coupler A	金属拖车钩 A
C3347	Coupler B	金属拖车钩 B
C3825	Rear Fender Set	前挡泥板

C3721	Rear Fender Set	后挡泥板
C3394	Transmission Shaft Assembly	金属传动轴
C3212V2	Transmission Gear Shift V2 For Rear Driver Function	变速箱轴 V2 (后驱功能)
C3340	Light Control System	灯控器
C3768	Front Rod Set	前拉杆散件
C3769	Rear Rod Set	后拉杆散件
C3830	15mm Magnet Set	15mm 圆磁铁
C3764V2	47T Spur Gear M0.8 ( Metal Gear) V2	47T 大直齿 M0.8 金属齿 V2
C3995	Pivot Balls D6*11.8	铝球头 D6*11.8
C3246V2	Steering Hron Arm V2	转向舵机臂 V2
C3789	25KG Metal Gear Servo Waterproof	25KG金属齿舵机
C4037	OVR Decal Sheel	OVR 车身心情贴纸
C4038	KC Light Cup Set	KC灯 套装
C3729	Rooftop Rack	行李架
C4039	Car Body Assembly Painted Green	车壳总成 绿色
C4040	Clear Car Body Parts	透明车壳散件套装
C4041	Wheel Assembly 1pair	车轮套装总成 一对
C4042	TOYO Tires	TOYO车轮胎 一对
C4052	Car Body Assembly Painted Black	车壳总成 黑色
C3948	SL 50A 2-3S Brushless ESC V2 For 1200KV Motor	SL 50A 2-3S 无刷电调 V2 (1200KV电机专用)
C3949	Brushless Version Wheel Shaft	无刷版 轮轴套装



EN:Wheel Set

CN:轮胎组

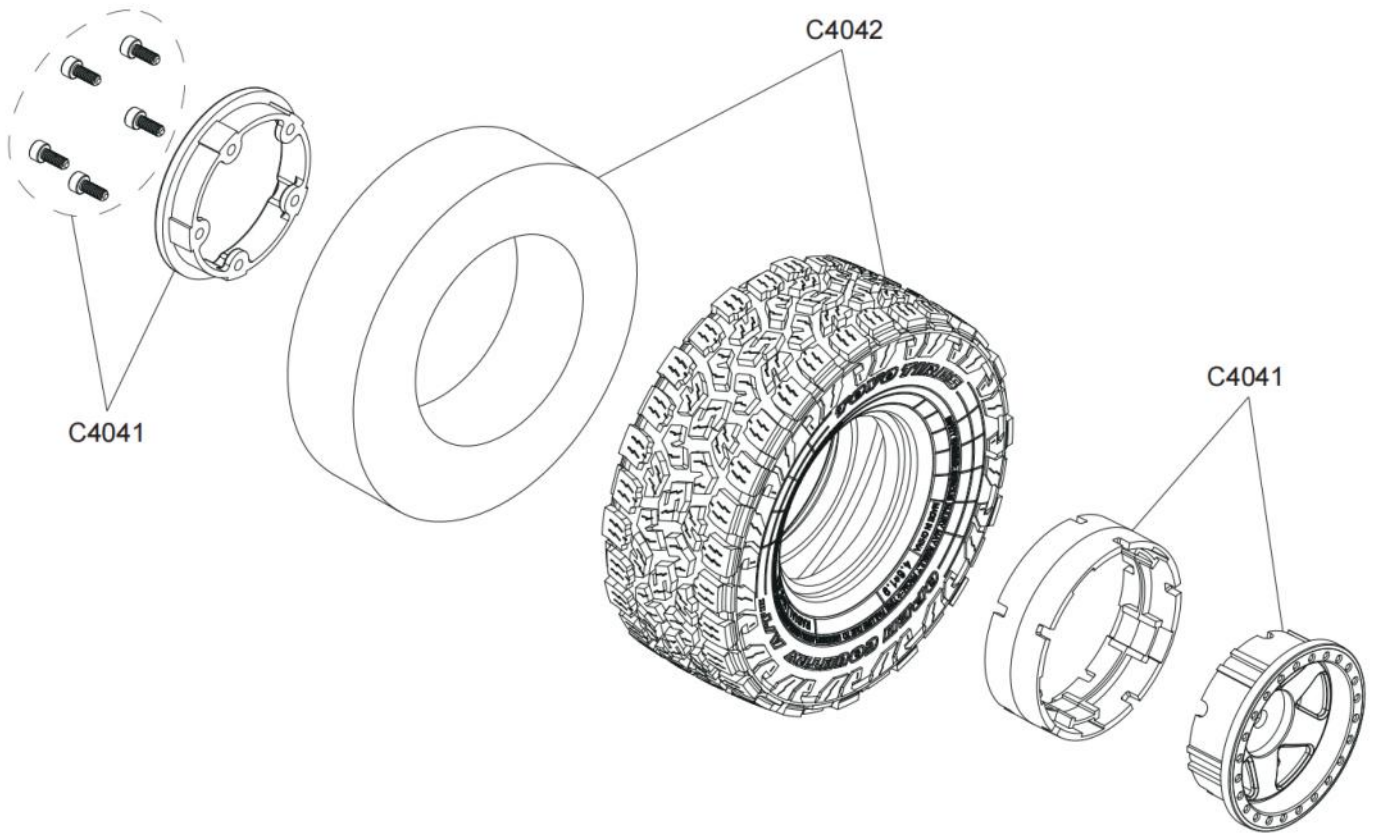

EN:Shift-gear Servo

CN:换挡舵机

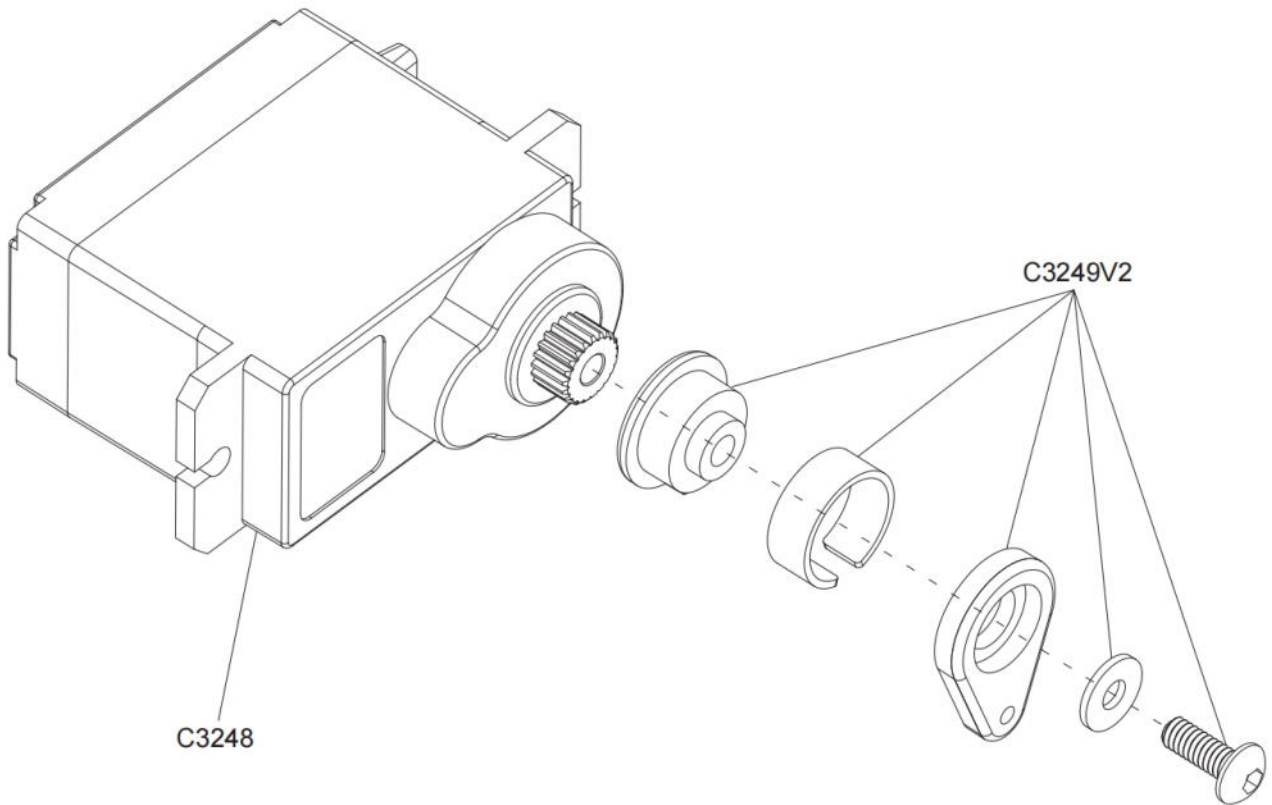

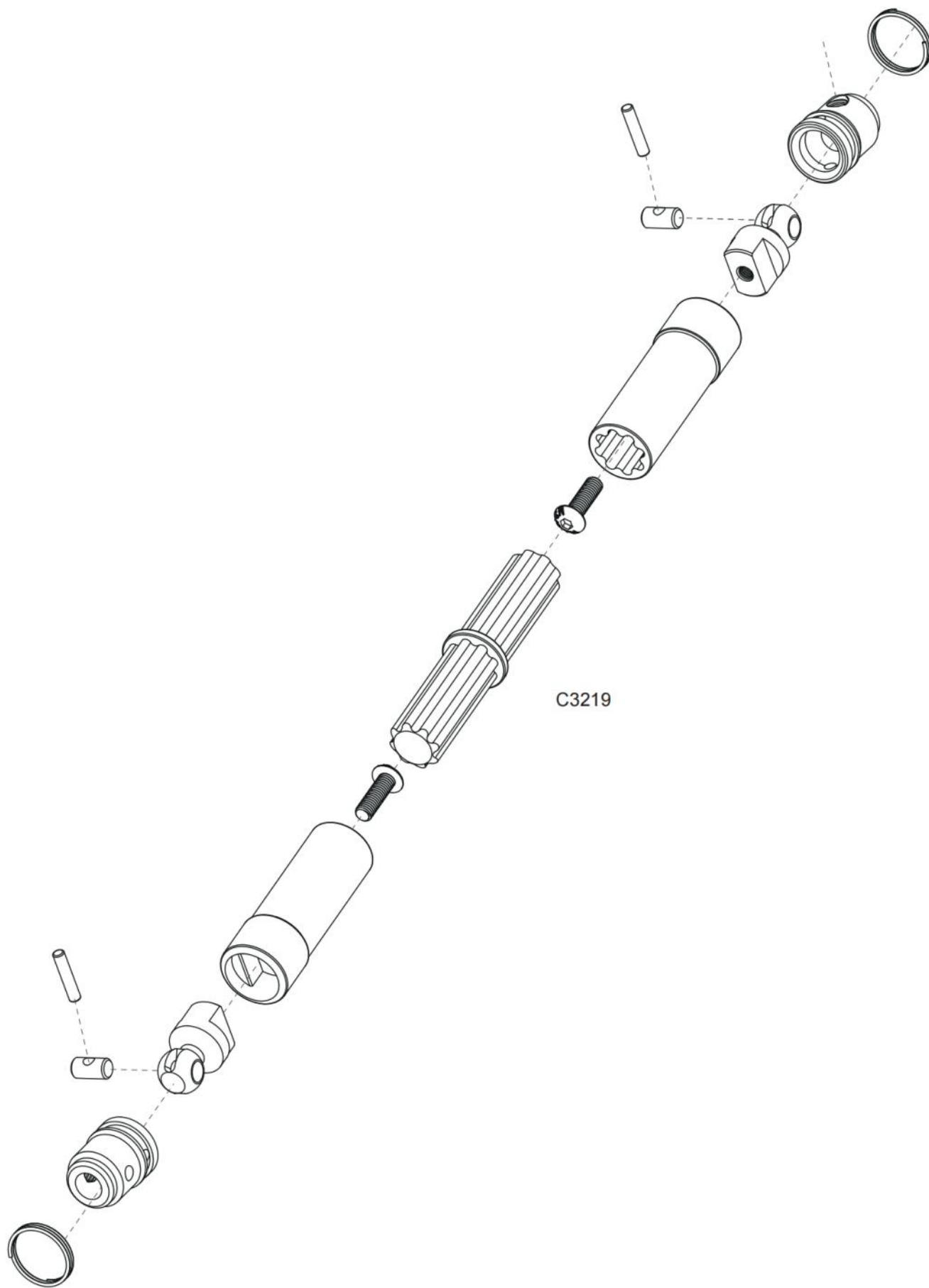

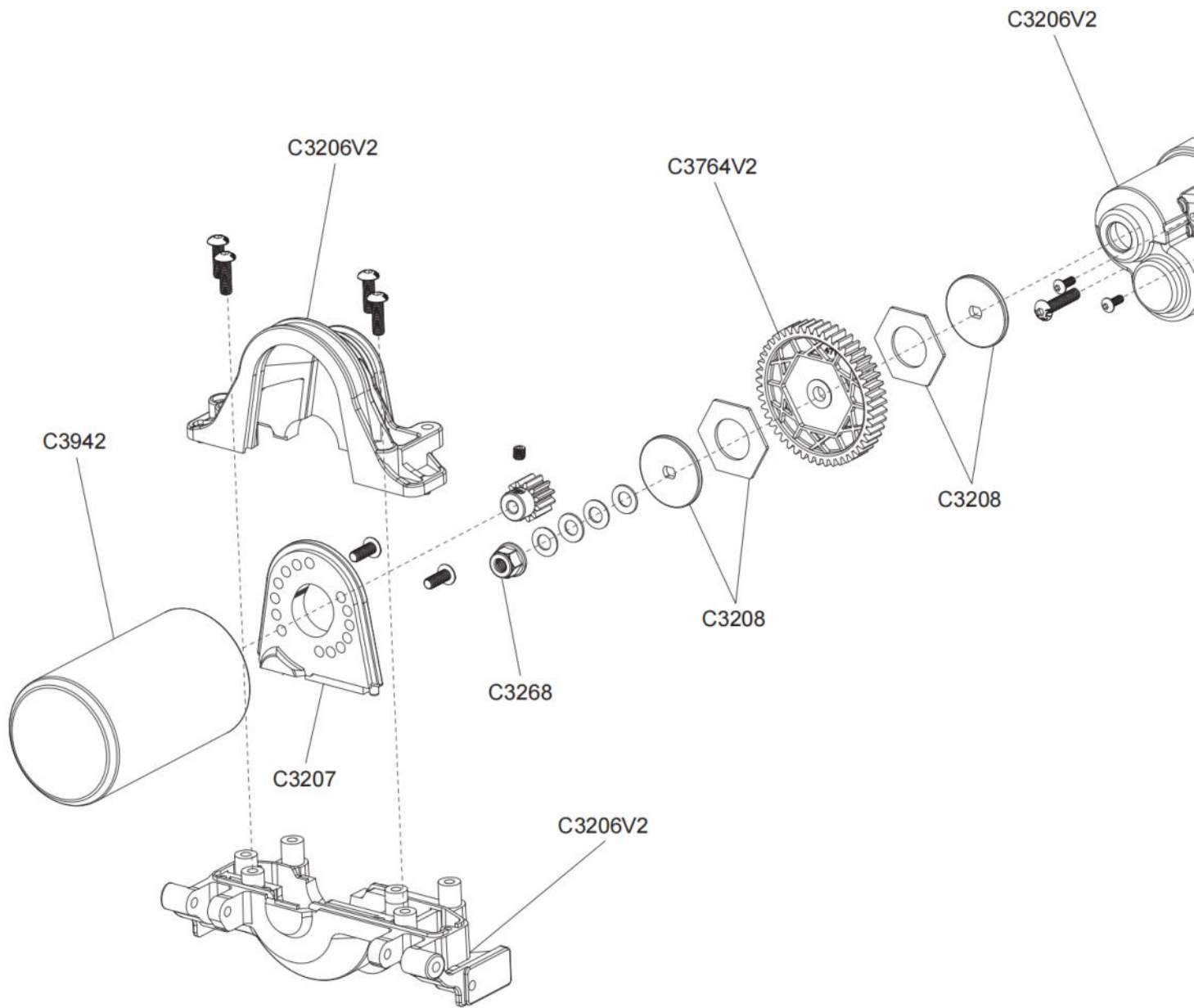

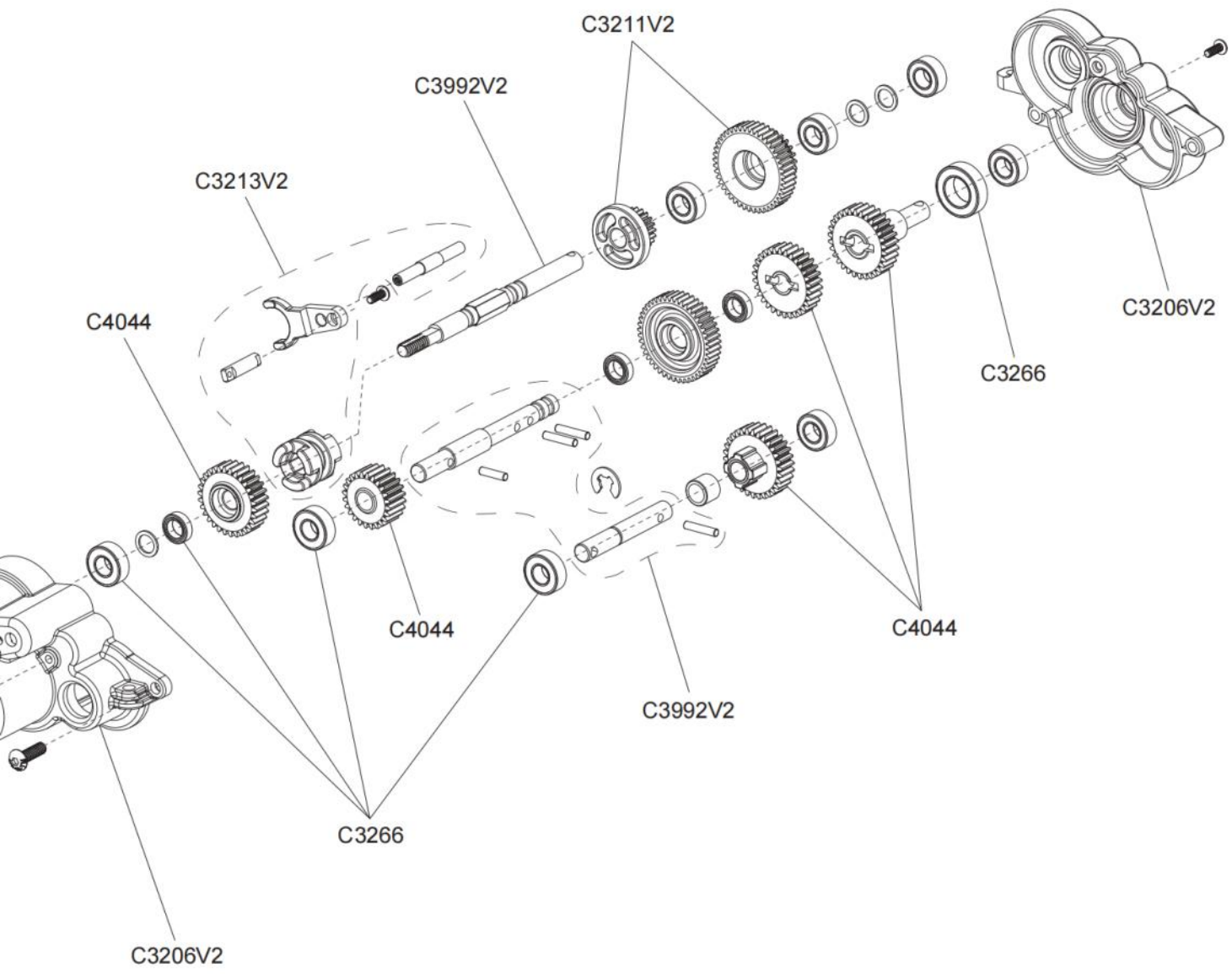

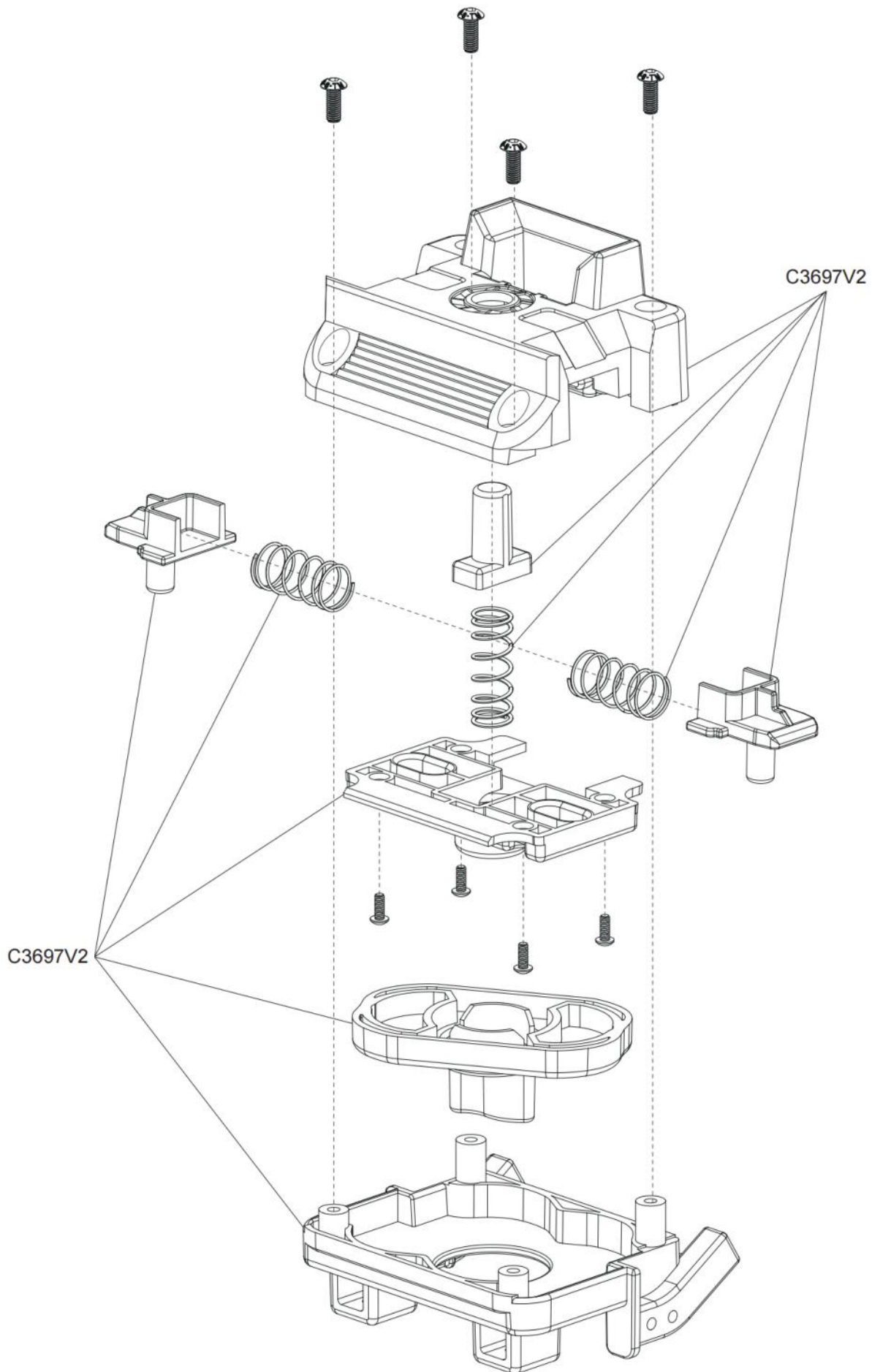

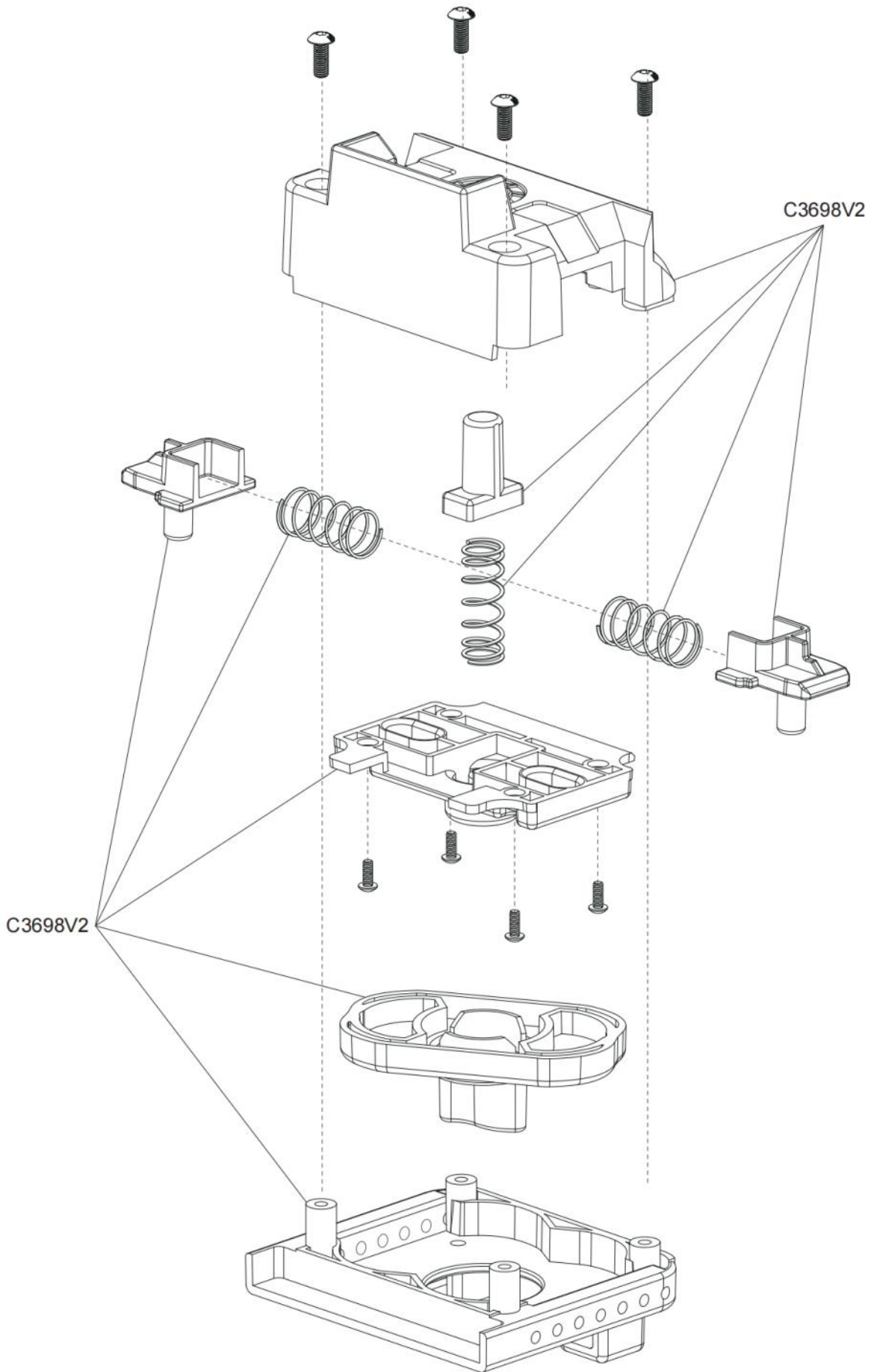

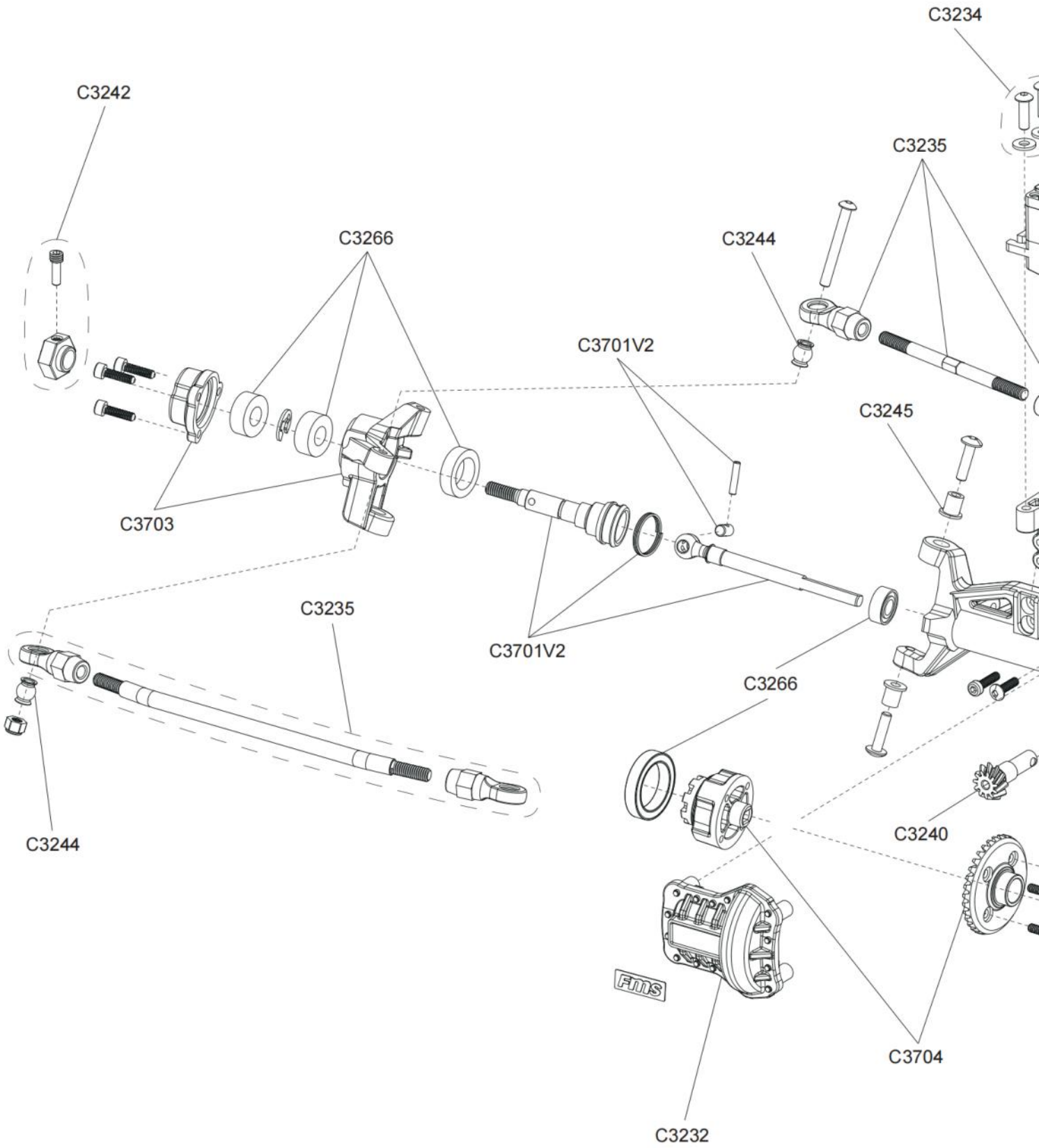

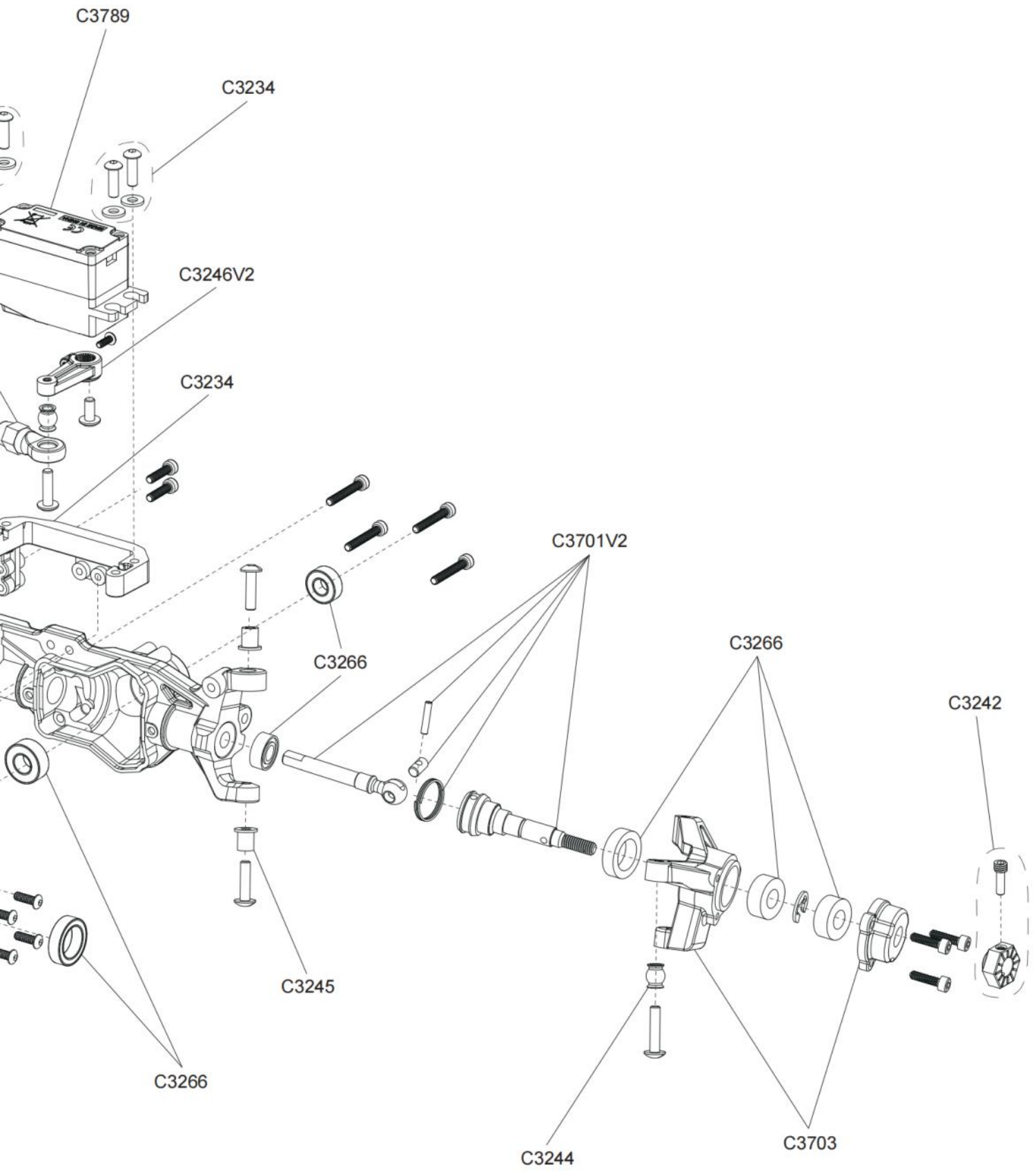

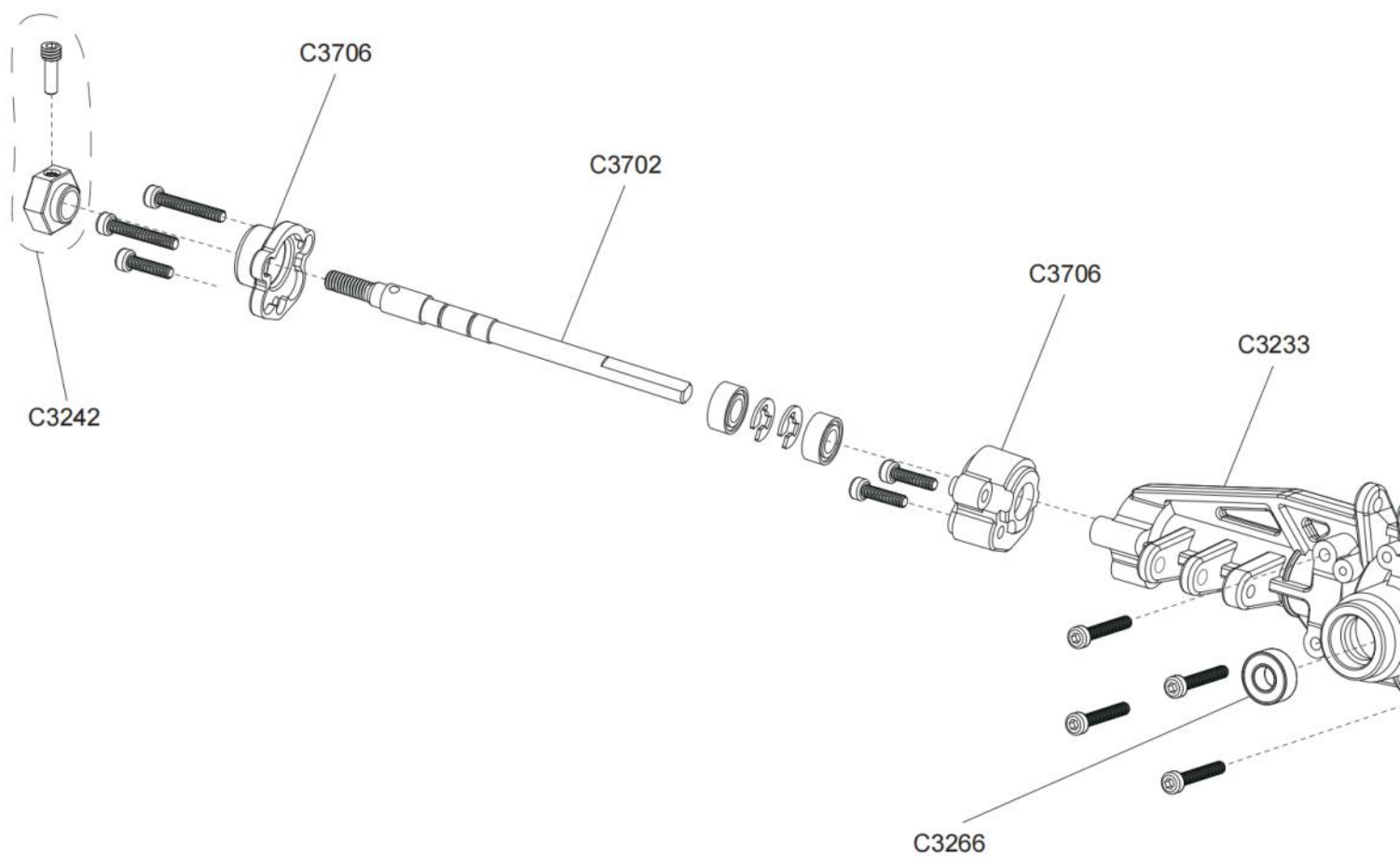

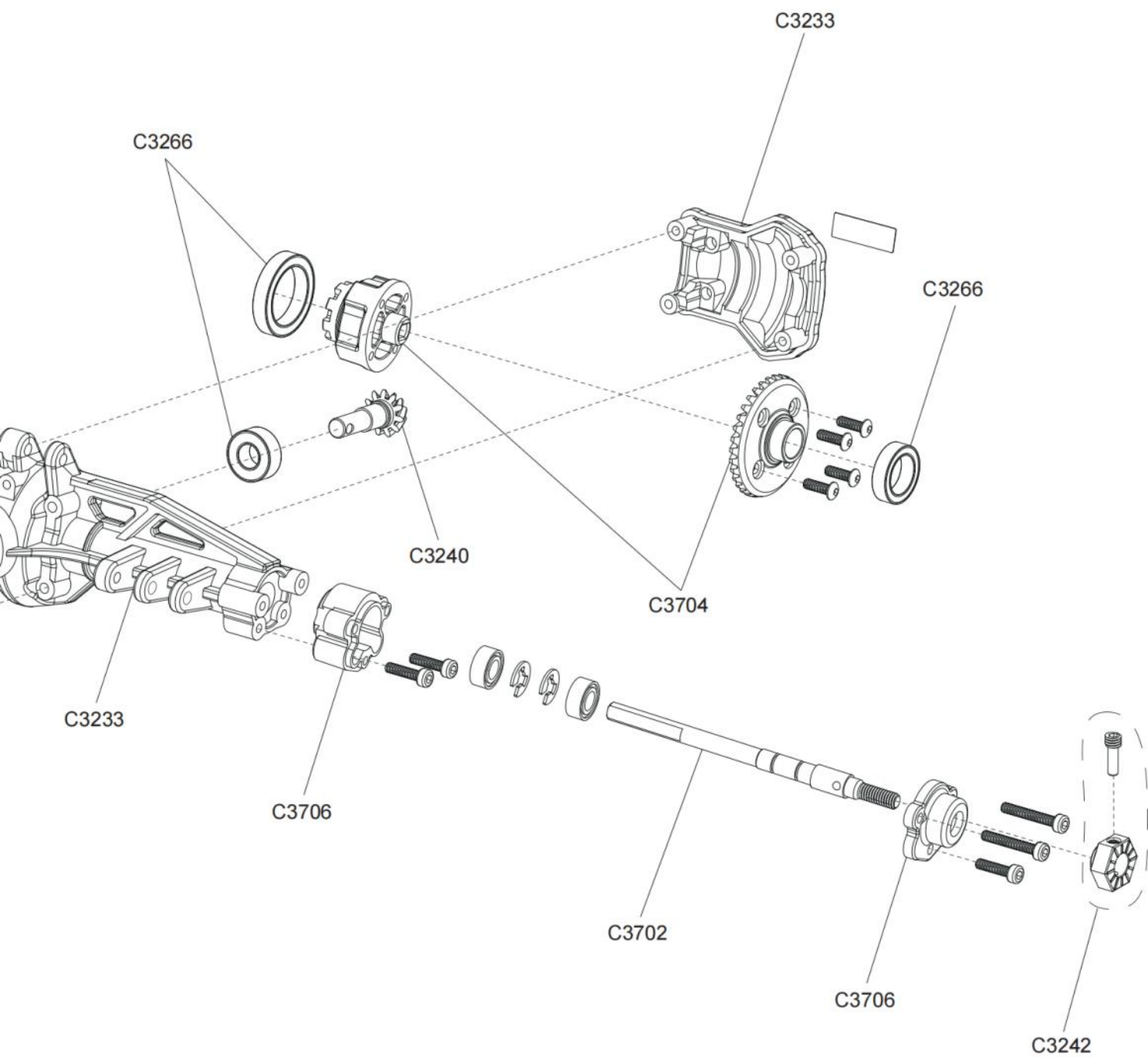

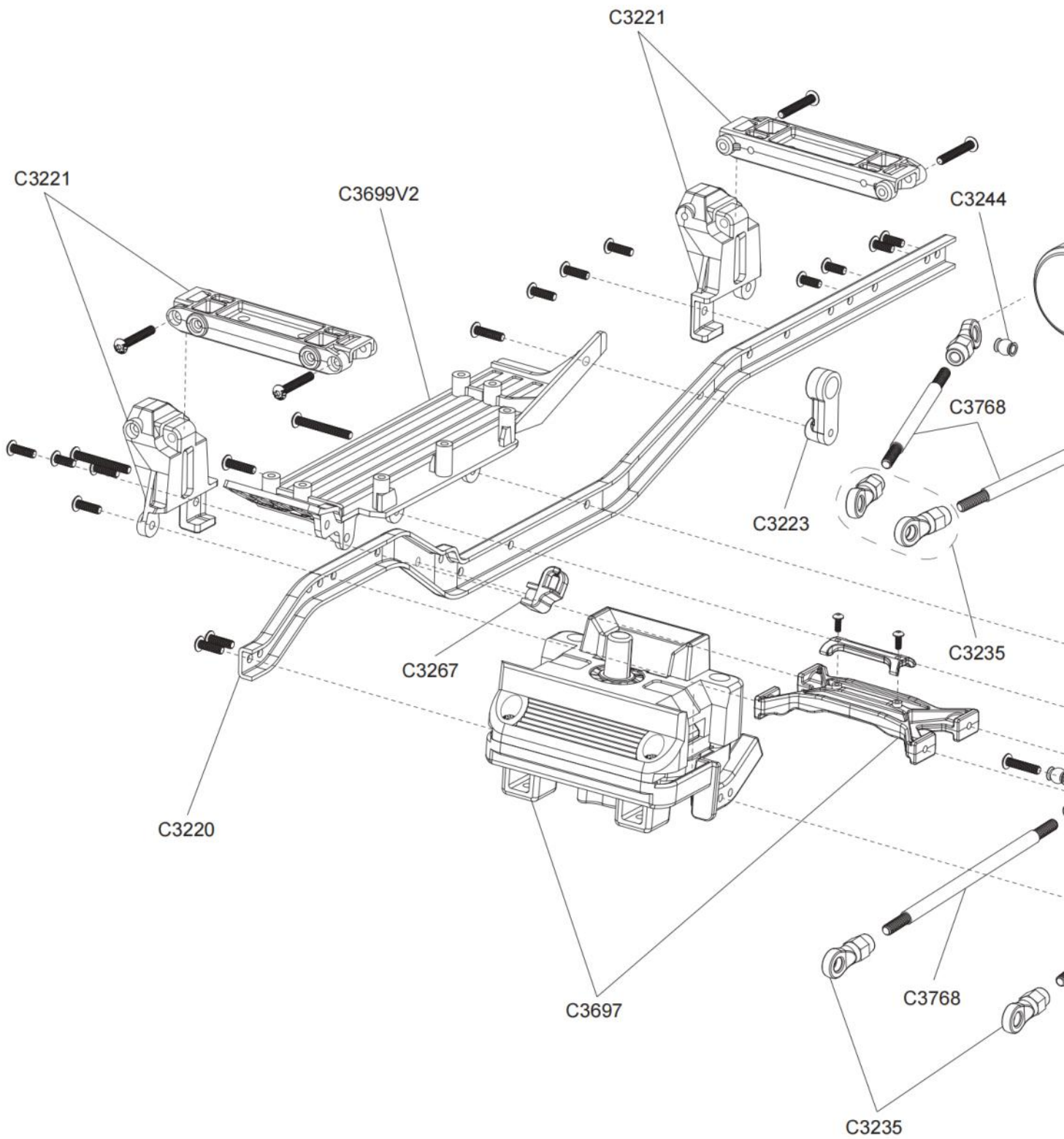

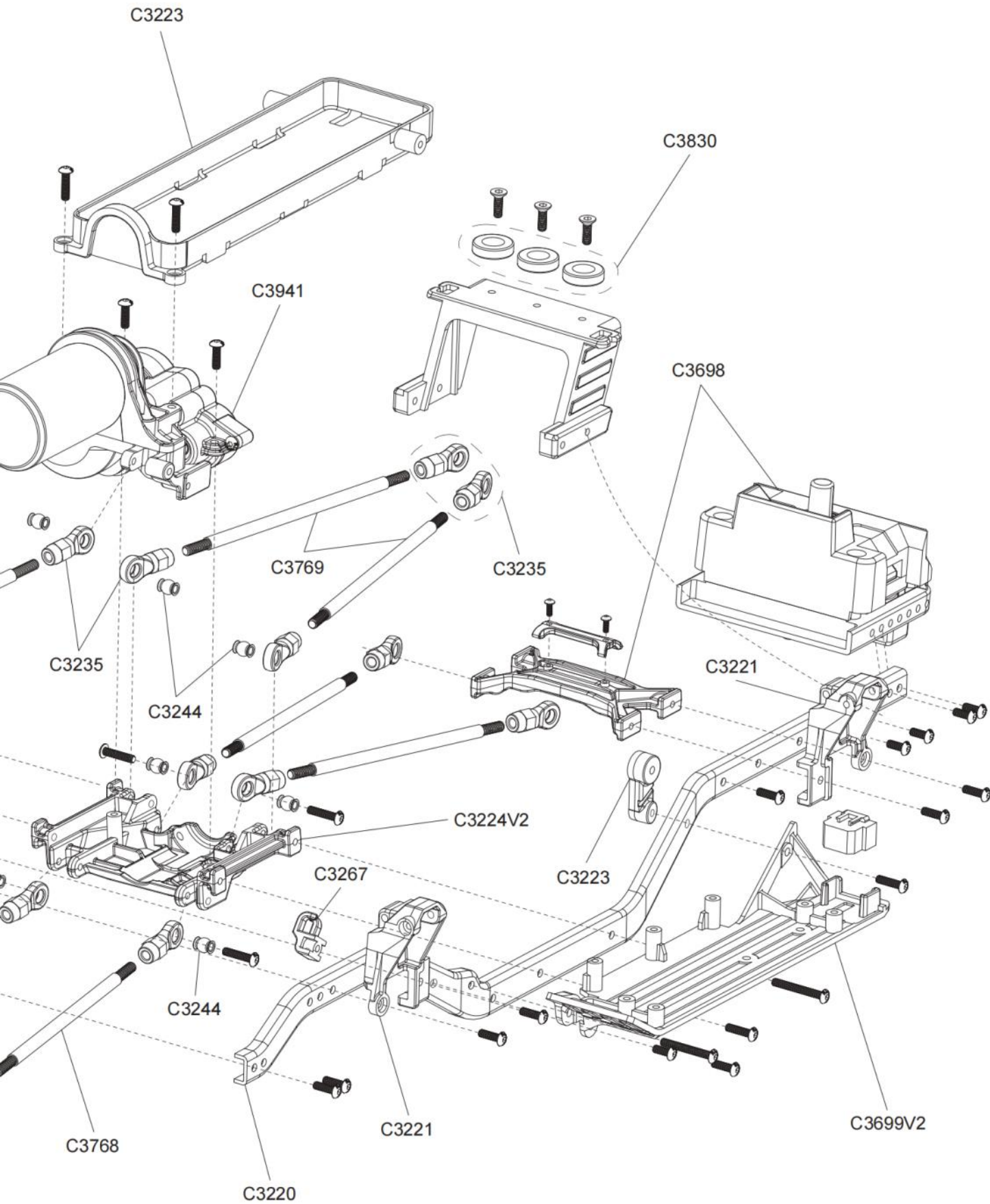

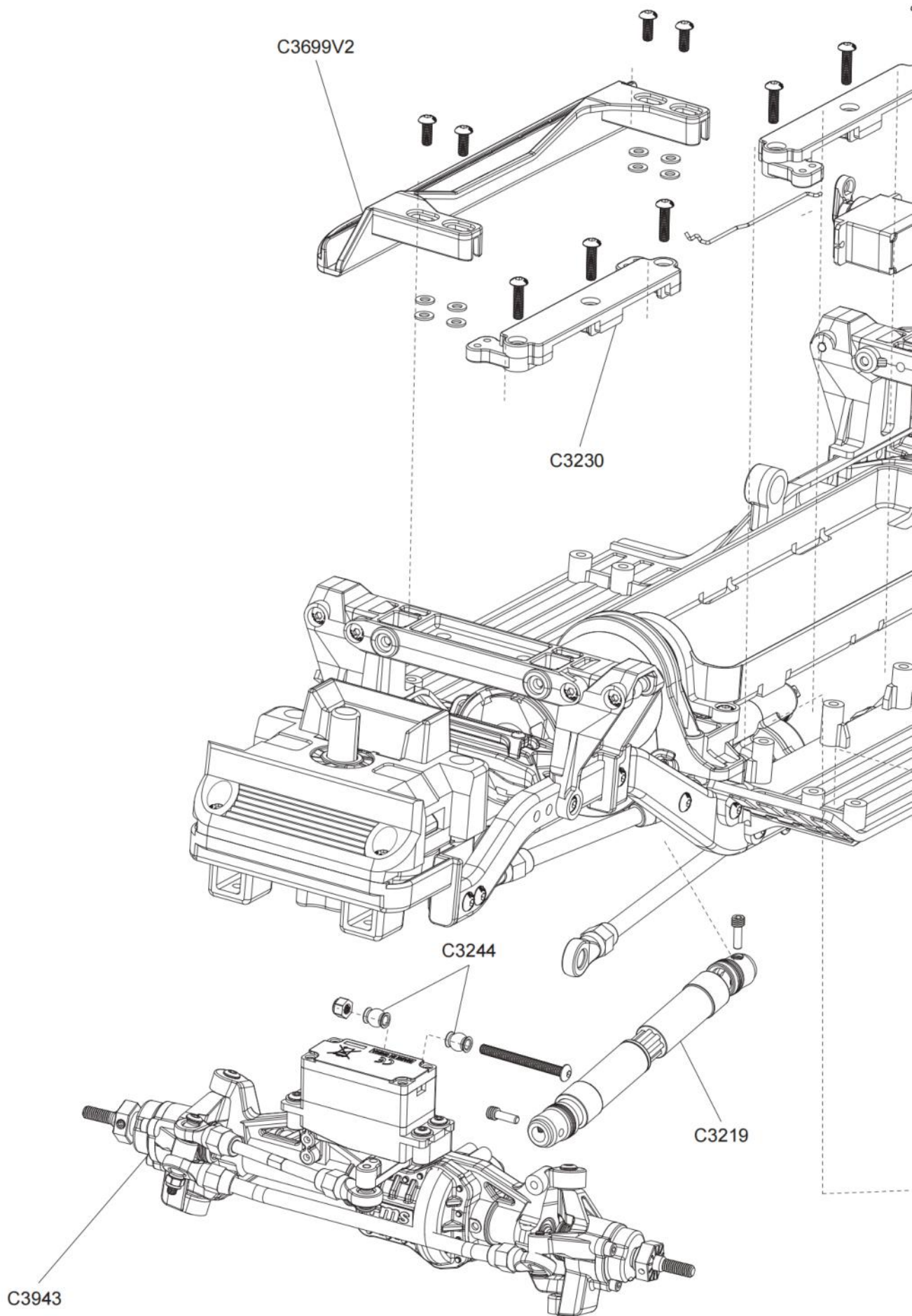

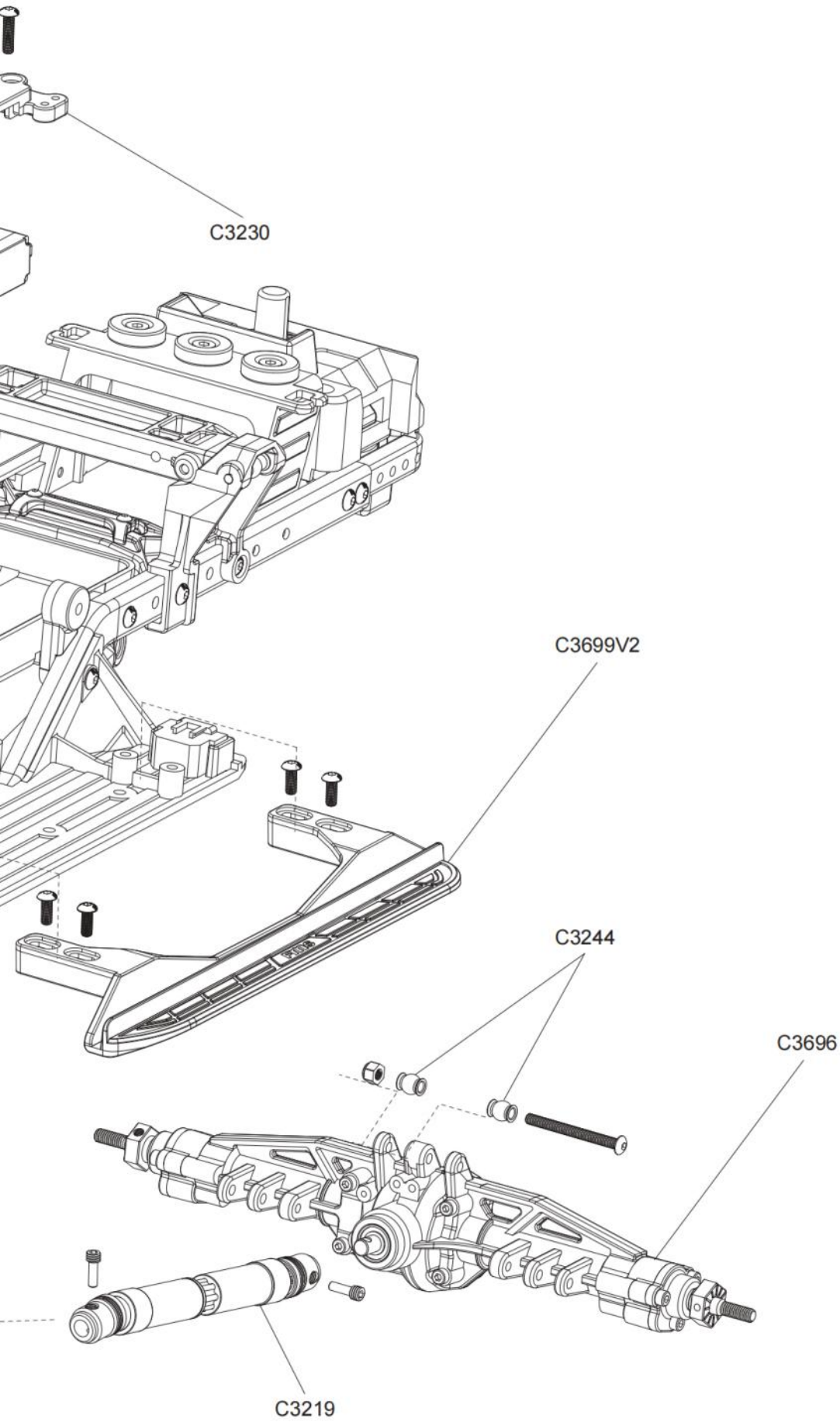

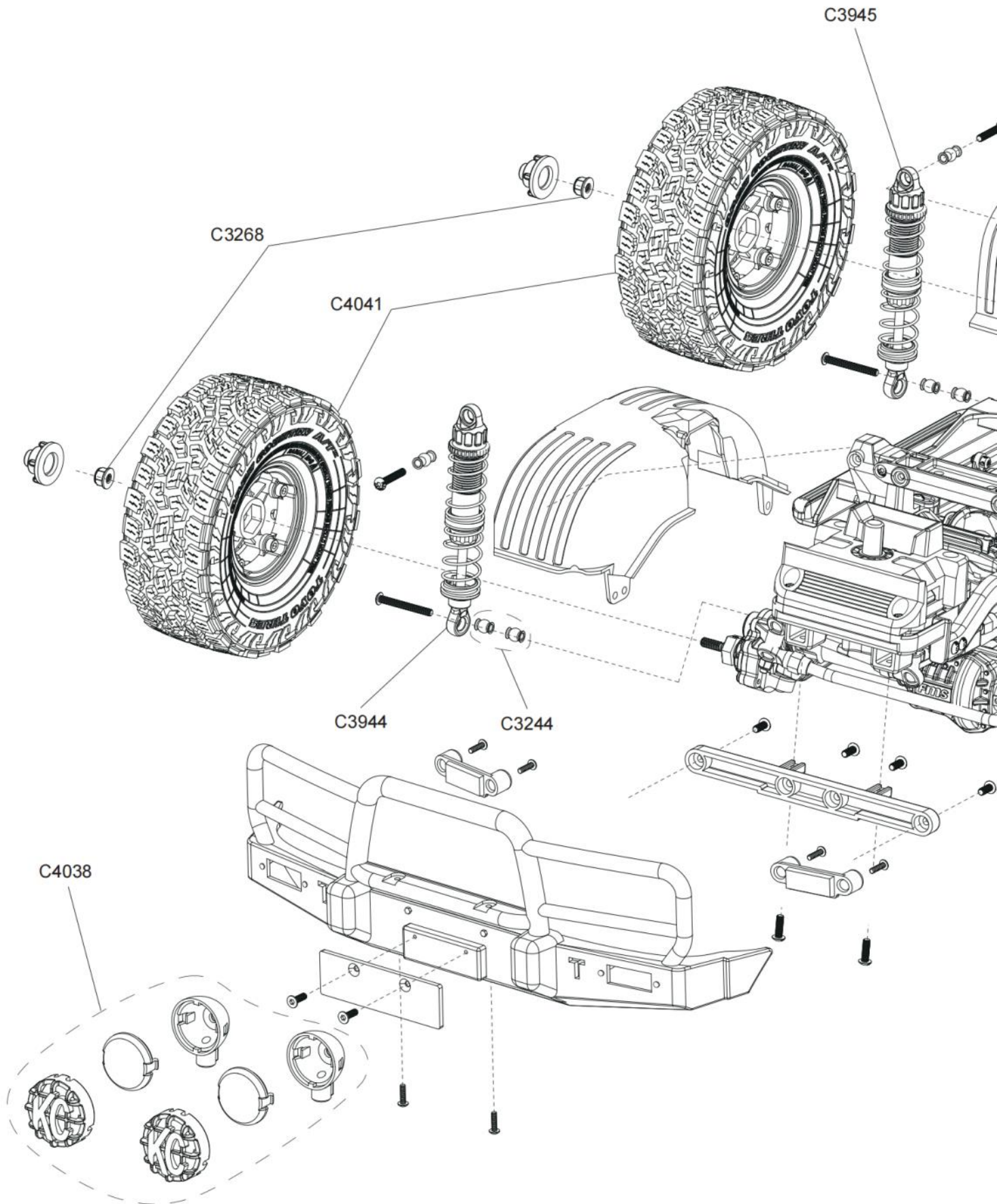

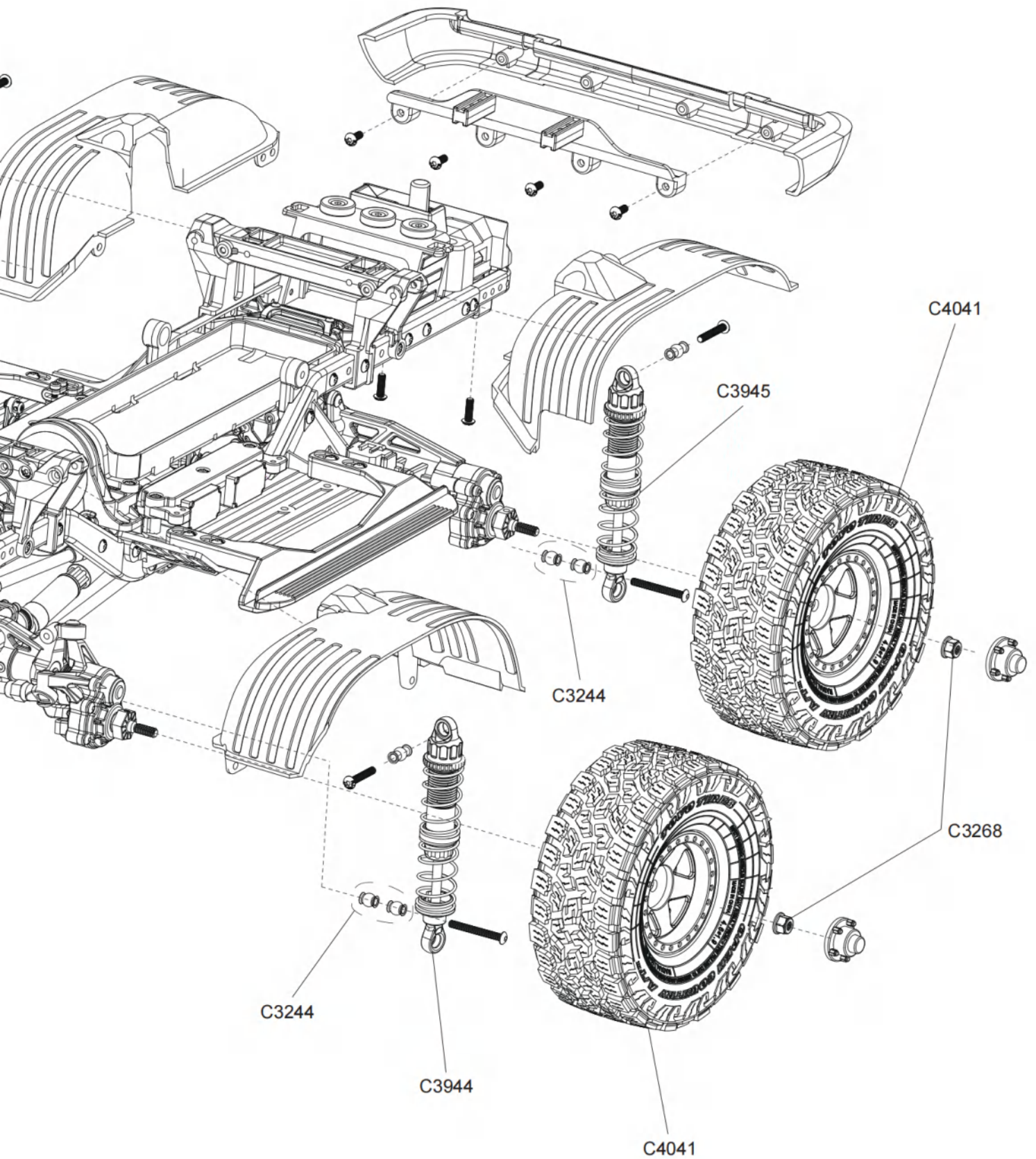

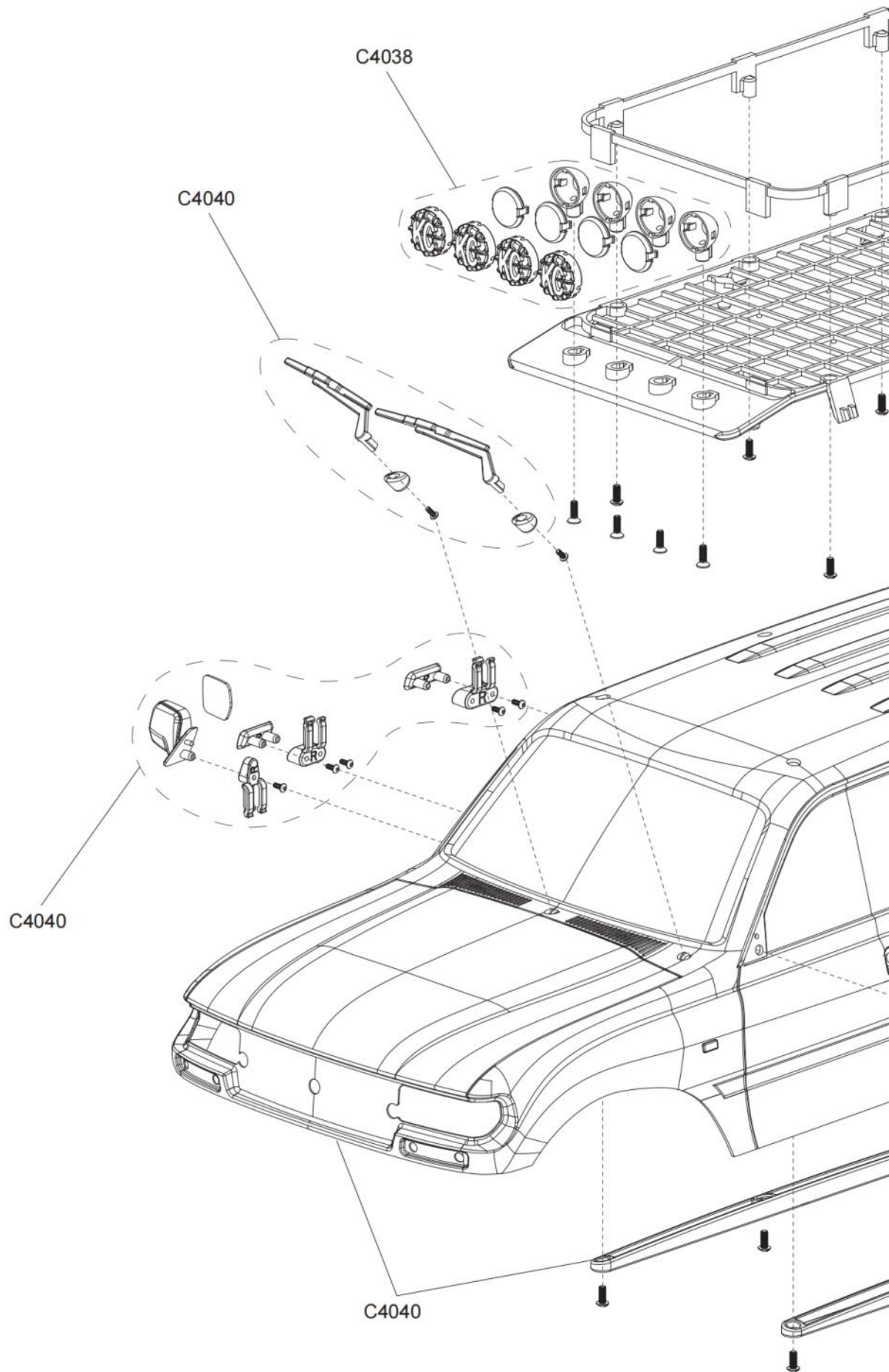

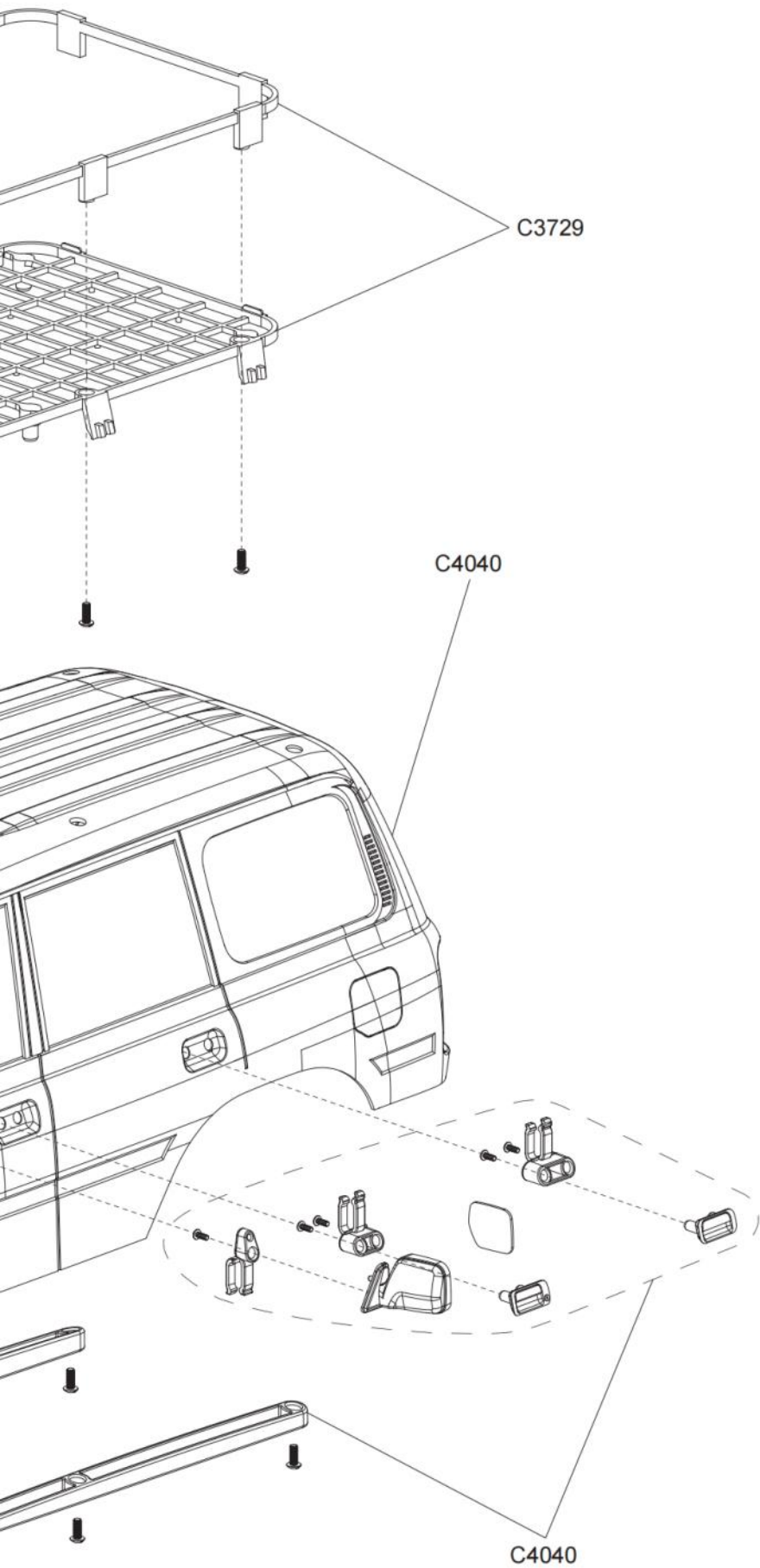

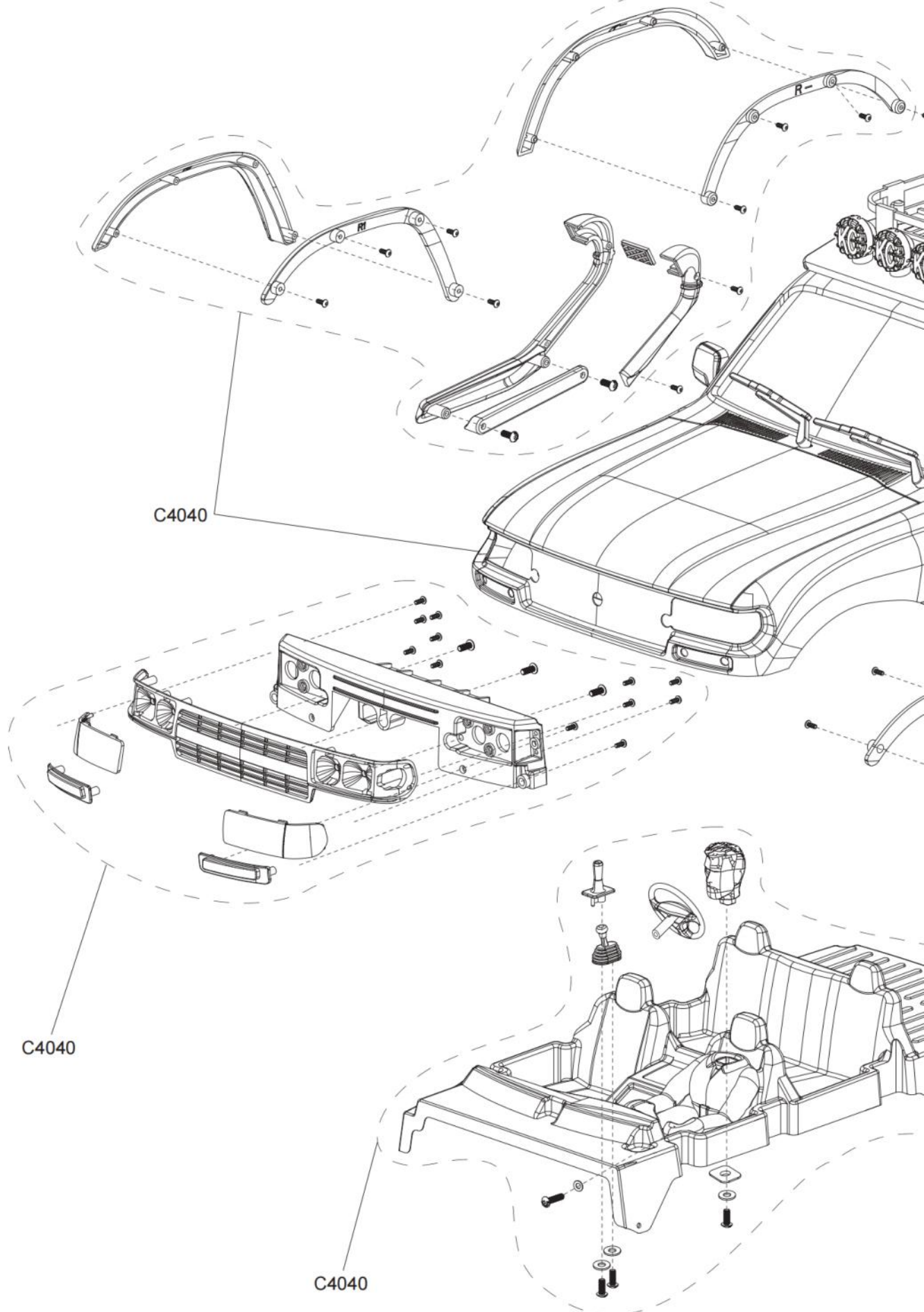

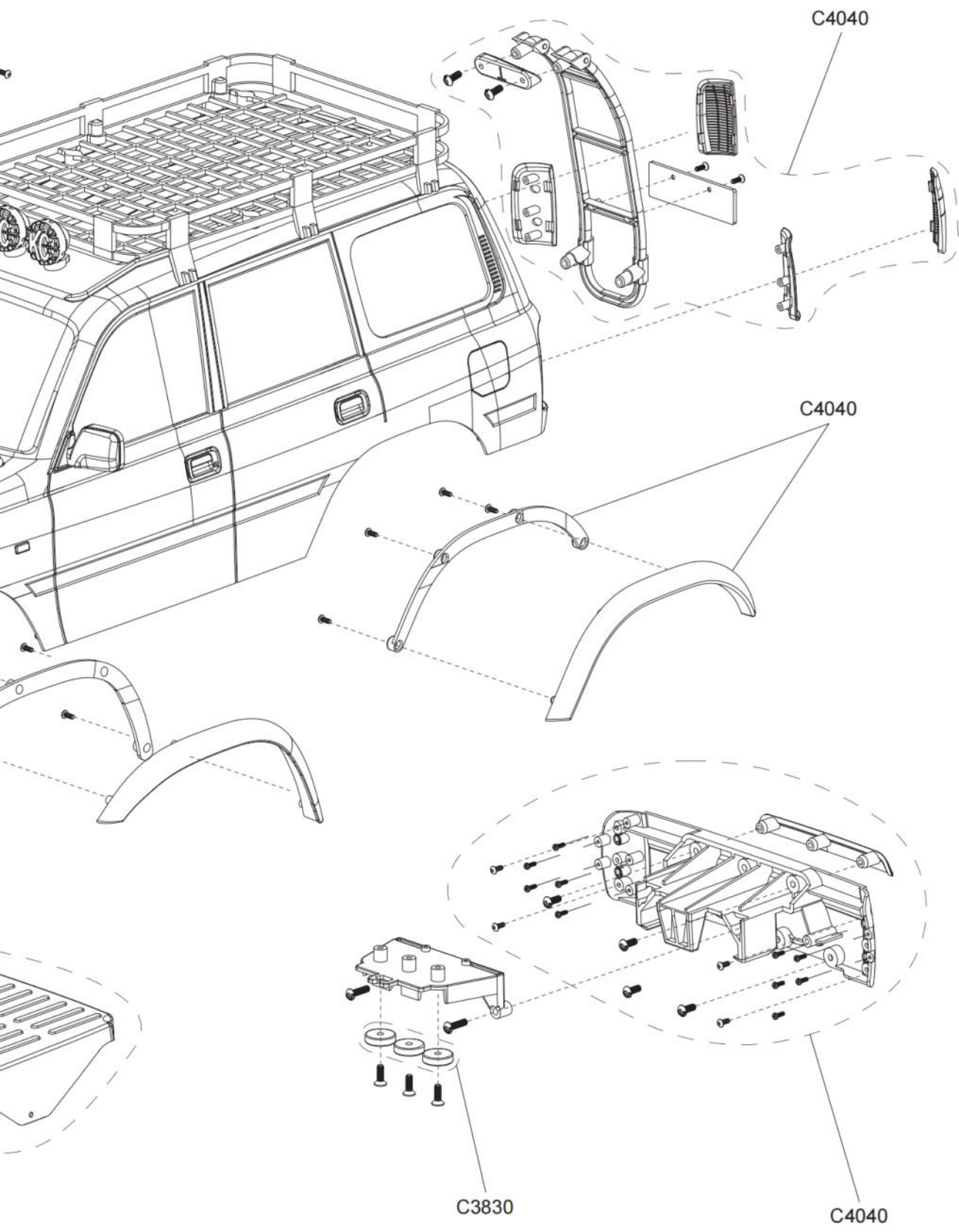

C4039/C4052

